

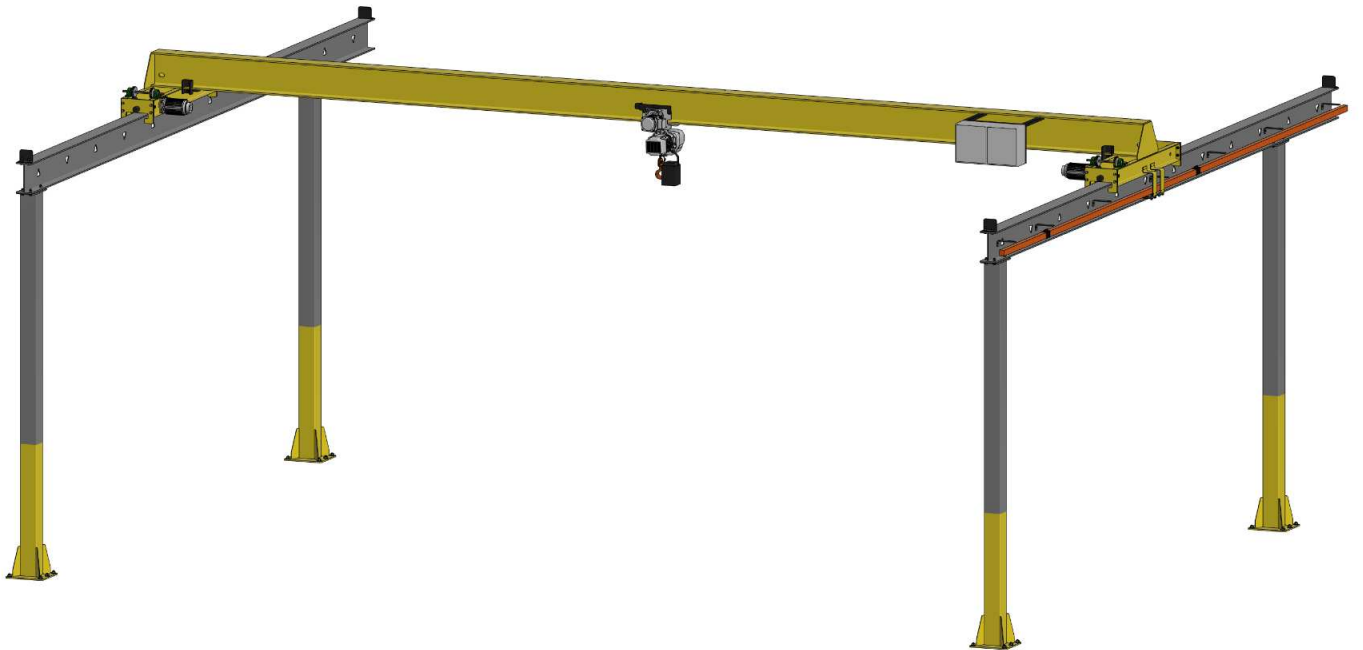

Motorized Top Runner Bridge Crane

Installation, Operation, & Maintenance Manual



FSTRM (1/2, 1, 2, 3 Ton) Owner's Manual

OWNERS RECORDS

Date purchased _____

Serial Number _____

Order Number _____

TABLE OF CONTENTS

Installation Safety	5
Pre-Installation Checklist & Capacity info	6
Pre-assembly & Column Installation	7
Runway Installation	8
Runway Splice Joint	9
Runway Alignment Tolerances	10
Runway End Stop & Bridge Installation	11
Bridge Electrification	12
Runway Electrification	13
Sway Brace Installation (Optional)	16
Final Steps	17
Crane Operator Instructions	17
General Safety	18
Operating Suggestions	19
Warranty	21-22
Periodic Inspection & Lubrication	23-25

Congratulations!

The PWI Crane System you have purchased is the result of years of engineering & design, and onsite assembly by our own installation crews. Long before this manual existed PWI had been building bridge crane systems across the USA. Our crane systems are built with years of experience, and we want you to know that we have put all that knowledge into what we have built for you. Please remember that our #1 goal is that you will have a successful installation and be very satisfied with your crane and how it operates.

Before you begin. Read the instructions carefully, from beginning to end, and follow the proper sequence. On the next page you'll find a safety section and general checklist that you should read before starting your installation.

Thank you from the entire staff at PWI.

PWI
7930 W 1000 N
Nappanee IN 46550

pwiworks.com
Phone: 574-646-2015
email: sales@pwiworks.com

General Safety

Safety comes first when unloading and assembling your bridge crane system. Many of the components are heavy and require lifting tools to move and set them in place. Make sure the equipment you choose to support and lift each piece is capable of the task with extra capacity to do the job so that you do not end up in a dangerous situation.

Start with checking any lifting fixtures/tools for damage or wear that could lead to severe injury or death.

This manual assumes that you have performed any foundation work ahead of placing your crane system columns in their proper location. Failure to provide the proper footing depth and width based on your column loads can result in failure of the floor structure supporting your crane. Please call PWI if you are unsure of the requirements for your PWI Crane System.

WARNING

Connections to building power supply. There are rules, regulations, and/or requirements about locating the power disconnect box at ground level. Please review information about the placement of your electrical power disconnect panel. (Not included)

WARNING

Clearance around bridge only. **There must be 3" above and 2" on the sides** between the bridge and any part of your facility.

Pre-Installation Checklist:

- Check your shipment for the correct components and hardware. Your shipment should include shipping sheets that were checked off by our team
- Check your shipment for drawings for layout and installation of components
- Clear the area as much as possible of items that could be damaged or create hazards during the installation. When assembling near Electrical panels be aware of any regulations regarding perimeters required around those objects
- Forklift or suitable lifting equipment
- Should you have any technical questions, or feel you have defective components or missing items, call us immediately. We will be glad to assist you.

Tools

- Markers, Tape Measures, Chalk Line, and Square
- Ladders/Man Lifts
- Hammer, Prybar, Clamps, and Line Up Punches
- Torque Wrench, Hand Wrenches, and Socket Set
- Leveling Tools (Level, Water Level, Laser Level)
- Lifting Equipment

System Capacity Information

The innovative design and heavy-duty construction of the PWI motorized top-runner system will provide a superior quality product that will offer years of long-term value. The hoist weight allowance is 15% of the cranes capacity (for example, a crane rated for 6000 pounds allows for a 6000-pound live load plus 900 pounds for the weight of the hoist). There is also an allowance of 15% of the crane capacity for impact caused by hoist use. PWI motorized top-runner systems will provide many years of dependable service by following the installation and maintenance procedures described herein.

Note: Any dimensions shown in this manual are for illustration purposes only. Refer to the drawings that were sent with your system for the exact measurements and configuration of the system we built for you.

Step 1. Pre-Assembly

If your floor surface is uneven Grout under the column base plates will be required to provide an even foundation to build on. Leveling nuts under the column base plate is an acceptable method that will aid leveling your system. (Shimming and Leveling nuts and Epoxy Anchors are not supplied with your system). If you must use grout under your columns to get a level system, use epoxy anchor bolts (not included) recommended. Epoxy anchors need to withstand 4880# of pull force. Contact PWI if you have questions.

Step 2. Laying Out Your Columns

- 2.1 Using the drawings supplied with your system verify that the area you are placing the crane system in will not encounter unforeseen obstructions. **Mark on the floor the center point of each column.** Look for obstructions that would require moving the system to avoid interference. (Example- proximity to electrical panels and controls, doors and walkways, wall switches, garage door openers & tracks, overhead obstructions)
- 2.2 Once you have found the best place for your system and have marked the column centers check that your marks are “square” by measuring diagonally from column center to column center. Once your system layout is correct and square you can **measure out from the center mark that you have made and sketch on the floor the outline of the column base plates.**
- 2.3 Stand the column up with a suitable lifting device and have help available to help hold the column in place while drilling (2) of the anchor holes for now. **Verify that the parts at the top of the column** will match the holes of your runway beam. Drill the (2) holes (check your paperwork supplied for sizes and torque specs of this hardware) diagonally across from each other to temporarily anchor the columns. Hint- Drill completely through the concrete floor. The minimum depth of the anchors is 4-1/2”.

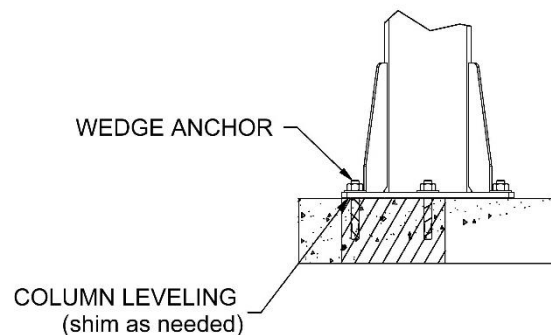

Step 3. Runway Installation

- 3.1 First identify the runway(s) with the Electrotrack brackets welded to one side of the beam web. These brackets are for mounting the electrification and need to be located toward the outside of the system. On the floor layout all the runway beams confirm the placement and alignment of these brackets.
- 3.2 Lift runway section onto top plates of column weldment (refer to enclosed Installation Drawing Set for recommended dimensions and runway location).
- 3.3 Using hardware (Structural Bolt, Plate Washer, Structural Washer, Structural Nut) provided, attach runway section to top plate of the column weldment as shown. Reference actual CAD drawings supplied with your system.

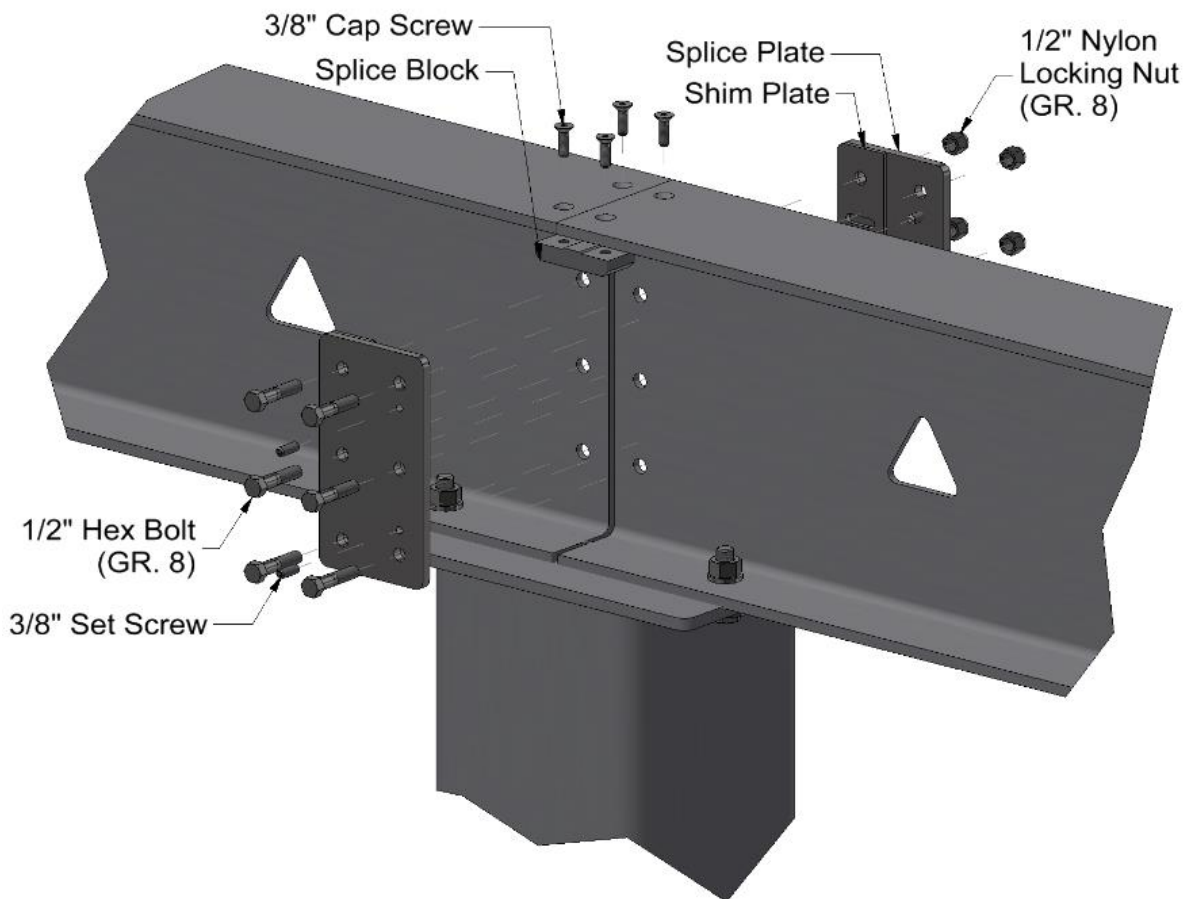

WARNING

There must be a minimum of two threads showing at the end of the bolt.

Bolt Size	Torque
9/16"	154 ft.-lb.
5/8"	212 ft.-lb.
3/4"	376 ft.-lb.
7/8"	606 ft.-lb.
Identification Mark	
Note: Grade 8 Hardware Required	

Bolt Torque Chart 3A

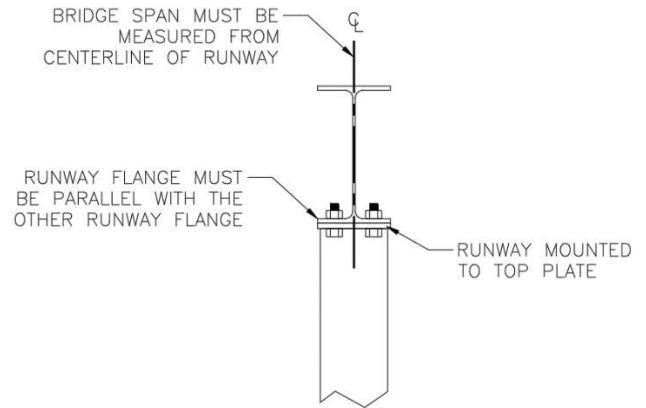

Runway Perpendicularity.

Note



Reference the **Installation Drawing Set** for splice locations. It will be necessary to install adjacent runways at the same time.

Splice Joint Instructions

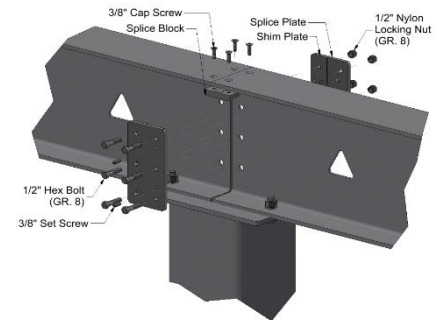
- 3.4 Set additional runway section(s) on top of column bringing the ends of the I-beam sections together as close as possible.
- 3.5 Attach additional runway I-beam section to top plate of the column using hardware listed in step 3.3. Shim to match the initial runway section.
- 3.6 Place I-beam web splice plate(s) (with the welded-on shim plate) on each side of the I-beam web (match holes). Align splice plate so that shim plate(s) are attached to each side of the **same** runway I-beam. Shim plates should be against the web of the beam.
- 3.7 Using set screws, adjust the other runway such that edges of runways align with each other.
- 3.8 Using Splice Block and Countersunk Cap Screw smooth out the top surface of the runways.
- 3.9 Check to see that the transition from one runway to the other is smooth: no raised areas to inhibit end truck operation.
- 3.10 For additional runways repeat Steps 3.4 through 3.9.

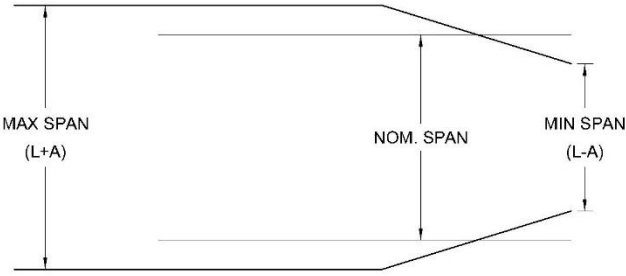
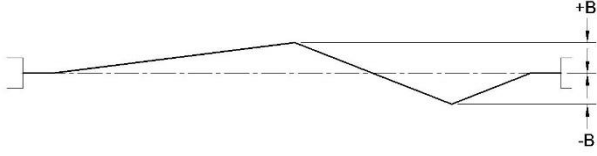

Runway alignment tolerance.

Item	Figure	Tolerance
<p>Crane Span (L)</p>		<p>$A = 3/16''$ In any Support Span</p>
<p>Straightness (B)</p>		<p>$B = 1/4''$ In any Support Span</p>
<p>Elevation (D)</p>		<p>$D = 1/4''$ In any Support Span</p>
<p>Girder-To-Girder Elevation (D)</p>		<p>$D = 1/4''$ Between Adjacent Runways</p>

Step 4. Runway End Stop Installation

- 4.1 End stops are required and must be installed at the end of trolley travel on bridge and at the end of bridge travel on runways.
- 4.2 Using hardware (Grade 8) provided, attach end stop to top of runway, as shown. Tighten hardware to proper torque (Chart 3A, Page 9).
- 4.3 Install end stops on bridge leaving one end finger tight to install hoist trolley, tighten hardware on the other end to proper torque (Chart 3A, Page 9).
- 4.4 The standard end stops are for normal application where contact with end stops is infrequent, and travel is at slow speed.
- 4.5 When service conditions are such that the bridge or trolley will contact end stops frequently or at high speed, energy absorbing type end stops are available and should be used. For details contact PWI.

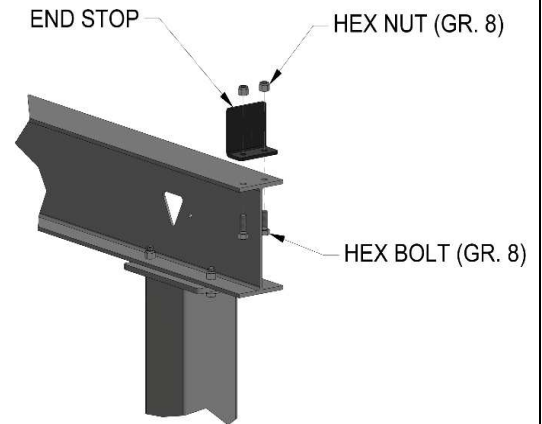

Diagram 4A End Stop Installation

Step 5. Bridge Crane Installation on Runways

- 5.1 Your PWI motorized top-runner bridge is fully assembled when shipped.
- 5.2 Install bridge by setting bridge on top flange of runway. Verify all fasteners are tight. (**Diagram 5A**)
- 5.3 Verify end stops are installed completely.

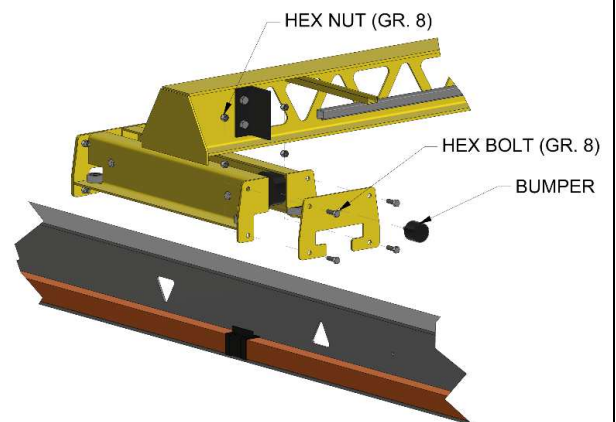

Diagram 5A

Step 6. Bridge Electrification Installation

Note: Typically, a motorized crane has been run and tested and is shipped ready to go. In this case move to step 7.

6.1 Standard electrification for the PWI motorized bridge is 4 conductor festoon wire. If the optional Starke Electrotrack was ordered, please go to **Step 7** for installation instructions.

6.2 If the festoon brackets and track are not pre-assembled use the hardware provided. Bolt the festoon bracket through the hole on the top flange of the bridge. Then bolt the festoon track through the hole in the festoon bracket (**Image 6A**)

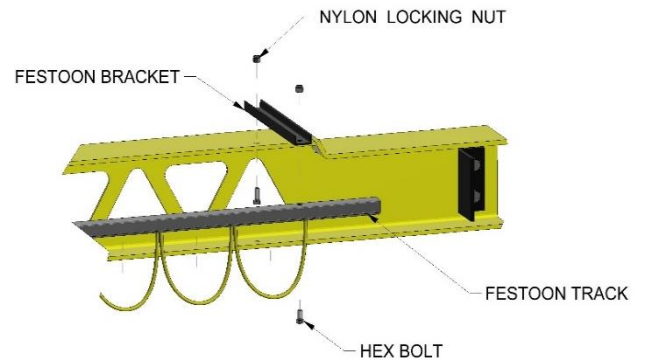

Image 6A. Festoon Installation

6.3 Loosen the wire clamp plate on the rolling festoon trolleys and roll trolleys into festoon track.

6.4 Next, on the end of the **festoon Track** that is closest to the **runway with electrification**, install the clamp type festoon wire hanger at that end of the festoon track.

6.5 Install festoon wire through festoon trolleys and festoon clamp. Making sure to have enough wire to make the connection to the runway electrification. Tighten festoon clamp. Position the festoon trolleys every 60" along the festoon wire and tighten clamp plate. Be sure not to over tighten as this could damage the festoon wire.

6.6 Both (Electrotrack & Hoist) ends of the festoon wire should have a twist lock plug(male) and socket(female). These connectors are typically provided by PWI. If not, use only twist lock connectors that are properly sized for the system. (**Image 6B**)

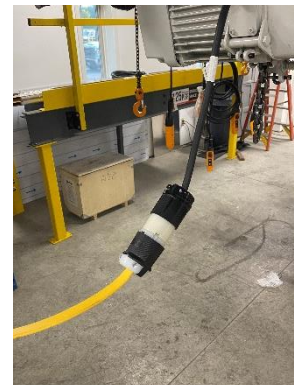

Image 6B. Connectors.

Step 7. Installing Runway Electrification (Electrotrack)

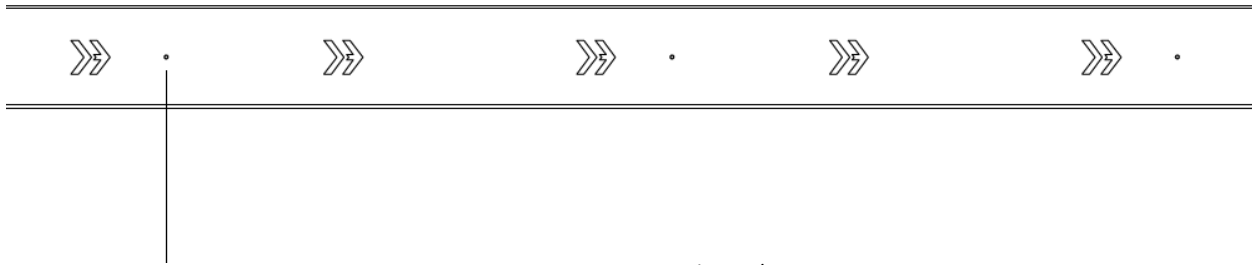

Image 7A. Mounting Hole.

- 7.1 Install electrification brackets into existing holes in runway beam web (shown above. **(Image 7A & 7B)**)
- 7.2 Install one Starke Electrotrack hanger for each bracket. Keep fasteners loose.
- 7.3 At the end of the system closest to building power supply install one full length Starke Electrotrack section to be used for “Incoming Power”. Drill a ¼” hole in each copper conductor rail to connect incoming power. Just drill holes at this time for wires to connect to later. **(Image 7C)**
- 7.4 Leaving a 4-6” gap install the second section, making sure the grounding conductors are oriented the same way. Note: each orange track is marked with a yellow and green line. This line indicates where the ground conductor is located.
- 7.5 Press a conductor coupler onto the dimpled end of each of the 4 conductors as far as it will go. Note: coupler body goes to the outside of the conductor leaving a smooth transition on the inside face of each coupler. **(Image 7D)**
- 7.6 Push the other conductors into the corresponding coupler. Once all 4 conductors are started, use a needle nose plier to work the conductors the rest of the way in. Conductor ends must be in tight contact. **(Image 7E)**
- 7.7 Place 1 half of a splice cover **(Image 7E)** around the conductor couplers and tight to the casing on both sides. 2 pins on the cover should align with 2 holes



Image 7B. Bracket.



Image 7C. Starter Rail

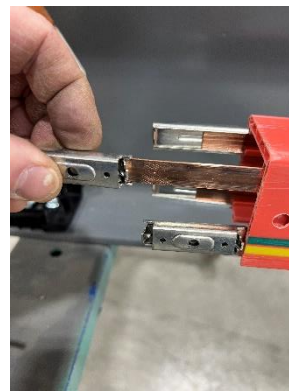

Image 7D. Splice.



Image 7E. Splice.

in the casing. **(Image F)** Clip the other half of the splice cover **(Image 7G)** into place locking rails together. Repeat **steps 7.4 - 7.7** as necessary until Electrotrack is complete.

- 7.8 Place the power supply box on the “Incoming Power” end of the rail. **(Image 7H)**
- 7.9 Place a bolt through each conductor hole so that the bolt head is between the conductors **(Image 7H)**
- 7.10 Place a terminal ring over the bolt on the outside of conductor followed with the nut.
- 7.11 With the power disconnected and verified with voltage tester connect supply wire to conductors. Starting with grounding terminal (green/yellow stripe) attach green wire then proceed clockwise with black, white, then red (red opposite to ground) **(Image 7H)**
- 7.12 Tighten the cord grip and tighten the connection nuts and bolts. Then slide the power supply box cover in place and install the power supply cover. **(Image 7I)**
- 7.13 At the other end of the Electrotrack install the collector trolley. Make sure the grounding brush (yellow wire w/green stripe) is aligned with the ground terminal of the Electrotrack. **(Image 7J)** Next, push brushes in and slide collector into Electrotrack. Depress the remaining brushes and slide collector trolley all the way in. **(Image 7K)**
- 7.14 Bridge and collector should then be lined up and the tow bar that guides the collector down through the Electrotrack can be attached to the bridge and surround the collector.



Image 7F. Splice.



Image 7G. Splice Cover



Image 7H. Supply Box.



Image 7I. Supply Box

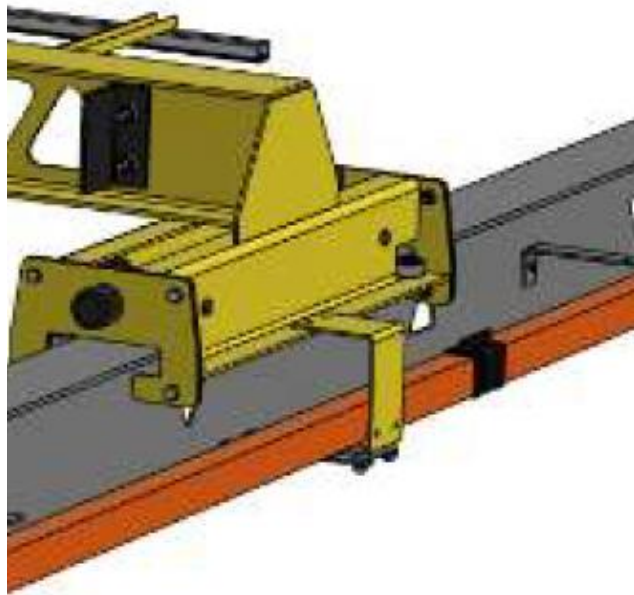

Image 7J. Ground



Image 7K. Trolley

7.1 Use the below photo to place your Electrotrack tow arm from the shipping position to the installed position.



NOTE: SWAY BRACING BY OTHERS

Step 8. Sway Brace (optional) Installation

Support assemblies are designed to AISC (American Institute of Steel Construction) specifications. If reduced movement of support assemblies is desired, then sway bracing (not included) can be added. The installer or end user must determine the possible locations of the bracing based on the specific application.

Bracing can be added in one of three formats, or a combination of any three.

A The most typical place to brace is directly to a building column. Providing a brace from a building column to the lateral (side) and longitudinal (lengthwise) axis of the support steel provides extreme rigidity throughout the system and requires only minimal locations (2 or 3 corners of the system is typically adequate, see **diagram 8A**).

B Another method is to brace back to the ceiling above the crane. Again, bracing at the corners of the system in both a lateral and longitudinal direction is sufficient (see 'B' in **diagram 8A**), providing the distance to the ceiling is not greater than 10 feet. For distances greater than 10 feet, additional points may need to be braced both laterally and longitudinally at the discretion of the end user and/or the installer.

C Finally, if the system is located at a point where it is not practical or possible to brace to the building columns or the ceiling structure, cross bracing can be used. This can be added at the sides of the system (see 'C' in **diagram 8A**) to control longitudinal sway, or across the open ends to limit lateral motion (not shown). This can also be added to the top of the system but should be checked to make sure that it does not interfere with the travel of the bridge.

It should be noted that the use of sway bracing is purely subjective because it is not a requirement of PWI, Inc. No specifications exist detailing appropriate methods, and the ultimate quantity and type is at the discretion of the user and installer. **If bracing, always determine if the building structure is adequate.**

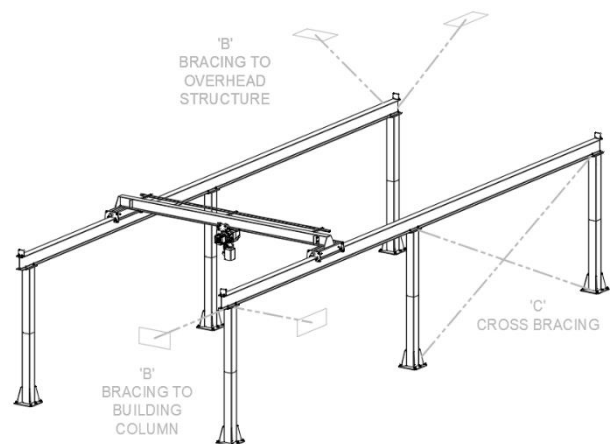

Diagram 8A. Examples of typical sway bracing locations.

➡ **TIP:** Do not throw away this manual: the maintenance schedule is included. Keep Packing List, Installation Manual, General Arrangement Drawing, and any other inserts filed together in a safe place.

Step 9. Final Steps

- 9.1 If sway bracing is desired (not required), be sure that crane is properly braced. Refer to Step 8, Sway Brace Installation.
- 9.2 Verify that all bolts are tightened to specifications.
- 9.3 Be sure all end stops are installed and functional.
- 9.4 Verify that the power supply is in conformance with crane specifications as ordered.
- 9.5 Load test is required (by others). It should be performed per latest ANSI B30.11 specification.
- 9.6 If necessary, touch up crane with paint provided.

CRANE OPERATOR INSTRUCTIONS

PWI Overhead cranes and jib cranes generally handle materials over working areas where there are personnel. Therefore, it is important for the Crane Operator to be instructed in the use of the crane and to understand the severe consequences of careless operation.

It is not intended that these suggestions take precedence over existing plant safety rules and regulations or OSHA regulations. However, a thorough study of the following information should provide a better understanding of safe operation and afford a greater margin of safety for people and machinery on the plant floor. It must be recognized that these are suggestions for the Crane Operator's use. It is the responsibility of the owner to make personnel aware of all federal, state, and local rules and codes, and to make certain operators are properly trained.

Qualifications

Crane operation, to be safe and efficient, requires skill: the exercise of extreme care and good judgement, alertness and concentration, and rigid adherence to proven safety rules and practices as outlined in applicable and current ANSI and OSHA safety standards. In general practice, no person should be permitted to operate a crane:

- Who cannot speak the appropriate language or read and understand the printed instructions.
- Who is not of legal age to operate this type of equipment.

- Whose hearing or eyesight is impaired (unless suitably corrected with good depth perception).
- Who may be suffering from heart or other ailments which might interfere with the operator's safe performance.
- Unless the operator has carefully read and studied this operation manual.
- Unless the operator has been properly instructed.
- Unless the operator has demonstrated his instructions through practical operation.
- Unless the operator is familiar with hitching equipment and safe hitching equipment practices.

Handling the Bridge Travel Motion

Before using the bridge of the crane, the operator should be sure the hook is high enough to clear any obstruction. Before a load is handled by the crane, the bridge should be put into position so that it is directly over the load. Start the load slowly and bring it up to speed gradually. Approaching the place where it is desired to stop the bridge, reduce the bridge speed.

Handling the Trolley Motion

Before a load is handled, the hoist should be positioned directly over the load that is to be handled. When the slack is taken out of the slings, if the hoist is not directly over the load, bring it directly over the load before hoisting is continued. Failure to center the hoist over the load may cause the load to swing upon lifting. Always start the trolley motion slowly and reduce the trolley speed gradually.

Handling the Hoist Motion

Refer to the lifting (hoist) equipment's operating instructions.

GENERAL SAFETY SUGGESTIONS

Know Your Crane

Crane operators should be familiar with the principal parts of a crane and have a thorough knowledge of crane control functions and movements. The crane operator should be required to know the location and proper operation of the main conductor disconnecting means for all power to the attachments on the crane.

Responsibility

Each crane operator should be held directly responsible for the safe operation of the crane. Whenever there is any doubt as to SAFETY, the crane operator should stop the crane and refuse to handle loads until: (1) safety has been assured or (2) the operator has been ordered to proceed by the supervisor, who then assumes all responsibility for the SAFETY of the lift.

Do not permit **ANYONE** to ride on the hook or a load.

Daily Inspection

Test the crane movement and any attachments on the crane at the beginning of each shift. Whenever the operator finds anything wrong or apparently wrong, the problem should be reported immediately to the proper supervisor and appropriate corrective action taken.

Operating Suggestions

One measure of a good crane operator is the smoothness of the crane operation. A good crane operator should know and follow these proven suggestions for safe, efficient crane handling.

1. The crane should be moved smoothly and gradually to avoid abrupt, jerky movements of the load. Slack must be removed from the sling and hoisting ropes before the load is lifted.
2. Center the crane over the load before starting the hoist to avoid swinging the load as the lift is started. Loads should not be swung by the crane to reach areas not under the crane.
3. Crane-hoisting ropes should be kept vertical. Cranes shall not be used for side pulls.
4. Be sure everyone in the immediate area is clear of the load and aware that a load is being moved.
5. Do not make lifts beyond the rated load capacity of the crane, sling chains, rope slings, etc.
6. Make certain that before moving the load, load slings, load chains, or other lifting devices are fully seated in the saddle of the hook with hook latch closed (if equipped with hook latch).
7. Check to be sure that the load and/or bottom block is lifted high enough to clear all obstructions when moving boom or trolley.
8. At no time should a load be left suspended from the crane unless the operator has the push button with the power on, and under this condition keep the load as close as possible to the floor to minimize the possibility of an injury if the load should drop. When the crane is holding a load, the crane operator should remain at the push button.
9. Do not lift loads with sling hooks hanging loose. If all sling hooks are not needed, they should be properly stored, or use a different sling.

10. All slings or cables should be removed from the crane hooks when not in use (dangling cables or hooks hung in sling rings can inadvertently snag other objects when the crane is moving).
11. Operators shall not carry loads and/or empty bottom blocks over personnel. Caution should be practiced when using magnet or vacuum devices. Loads, or parts of loads, held magnetically could drop. Failure of power to magnets or vacuum devices can result in dropping the load. Extra precautions should be exercised when handling molten metal in the proximity of personnel.
12. Whenever the operator leaves the crane, the following procedure should be followed:
 - Raise all hooks to an intermediate position.
 - Spot the crane at an approved designated location.
 - Place all controls in the “off” position.
 - Open the main switch to the “off” position.
 - Make visual check before leaving the crane.
13. In case of emergency or during inspection, repairing, cleaning or lubrication, a warning sign or signal should be displayed, and the main switch should be locked in the “off” position. This should be done whether the work is being done by the crane operator or by others.
14. Contact with rotation stops or trolley end stops shall be made with extreme caution. The operator should do so with particular care for the safety of persons below the crane, and only after making certain that any persons on the other cranes are aware of what is being done.

ANY SAFETY FEATURES AND MECHANISMS BUILT IN OR OTHERWISE PROVIDED WITH THE ULTRA-LITE CRANE BY PWI ARE REQUIRED FOR THE SAFE OPERATION OF THE CRANE. DO NOT, UNDER ANY CIRCUMSTANCES, REMOVE OR OTHERWISE IMPAIR OR DISABLE THE PROPER FUNCTIONING OF ANY CRANE SAFETY MECHANISMS OR FEATURES BUILT-IN OR OTHERWISE PROVIDED BY PWI FOR SAFE OPERATION OF THE CRANE. ANY REMOVAL, IMPAIRMENT OR DISABLING OF ANY SUCH SAFETY MECHANISMS OR FEATURES OR OTHER USE OR OPERATION OF THE CRANE WITHOUT THE COMPLETE AND PROPER FUNCTIONING OF ANY SUCH SAFETY MECHANISMS OR FEATURES AUTOMATICALLY AND IMMEDIATELY VOIDS ANY AND ALL EXPRESS AND IMPLIED WARRANTIES OF ANY KIND OR NATURE.

LIMITED WARRANTY

STRUCTURAL: 3-Year (36 Month) Parts & Workmanship Warranty

Structural items include but are not limited to columns, headers, runways, and other stationary components of this PWI Ultra Lite System.

Unless otherwise specified, PWI guarantees that the structure or this product is free from material defects in design, materials, and workmanship under normal use, proper maintenance, and service. A corrosive or abrasive atmosphere is not to be considered a normal atmosphere.

This warranty is strictly limited to 36 months for single shift operation or 6,000 hours after installation, or 38 months after shipment, whichever is shorter. Within ten days after a defect is found, warrantee must deliver a written notice to PWI. All requested warranty information must be received promptly by PWI in no more than 5 business days.

MECHANICAL: 1 Year (12 Month) Parts & Workmanship Warranty

Mechanical items include but are not limited to all types of Overhead Cranes, and other non-stationary PWI products that are designed for specific functional operation.

Unless otherwise specified, PWI guarantees that this mechanical product is free from material defects in design and workmanship under normal use, proper maintenance, and service.

This warranty is strictly limited to 12 months for single shift operation or 2,000 hours after installation, or 14 months after shipment, whichever is shorter. Within ten days after a defect is found, warrantee must deliver a written notice to PWI. All requested warranty information must be received promptly by PWI in no more than 5 business days.

All standard non-engineered products including but not limited to hoists, trolleys, wheels, gearmotors, controls, and safety products, will fall under the default warranty of that specific manufacturer.

GENERAL:

This warranty will not apply to any product that has been repaired or altered outside of PWI manufacturing plant, or without specific instructions from PWI to make alterations. PWI will in no case allow or offer reimbursement for outside sources to perform repairs or make alterations to product in reference. If the product has (in PWI's judgment), had alterations made which adversely affect its serviceability or was subject to misuse, negligence, accident, or operated contrary to instructions or common practice, warranty shall be considered void.

Defective items will be repaired or replaced and returned to PWI at the cost of the owner. If PWI, at its discretion, finds the warranty claims to be justifiable, PWI will compensate by means of replacing or repairing faulty products or components free of charge. The sole liability of PWI for warranty claims is limited to those here. In no event will PWI be liable for damages in excess of the original sale price of the defective product, or for any consequential damages, nor will PWI be liable for any special or other work done unless specifically agreed to in writing. This warranty does not include or apply to fire, natural disasters, or other Acts of God.

Should the warrantee destroy, intentionally or not, any part of the warranted product, or any evidence concerning the origin of an alleged defect, or try to conceal evidence of causation, this warranty is cancelled, and warrantee will have no claim against PWI whatsoever.

This warranty does not cover coatings on any PWI products including paint, powder-coat, zinc, or galvanized coatings. Coating life can vary greatly based on the ambient environment your PWI product is installed in, which is simply out of the manufacturer's control. Touch-up painting or coating repair (after initial installation by PWI or customer) shall be the responsibility of the owner, unless specifically guaranteed in writing on project quotation.

Any interpretation of this warranty shall be done in common pleas court in Indianapolis under Indiana law.

ALL OTHER REPRESENTATIONS, EXPRESS OR IMPLIED, WARRANTY, OR LIABILITY RELATING TO THE CONDITION OR USE OF THE PRODUCT ARE SPECIFICALLY, DISAVOWED, AND IN NO EVENT SHALL PWI BE LIABLE TO BUYER, OR ANY THIRD PARTY, FOR ANY DIRECT OR INDIRECT CONSEQUENTIAL OR INCIDENTAL DAMAGES

PERIODIC INSPECTION AND LUBRICATION RECOMMENDATIONS

The following is a checklist to be followed in performing periodic inspections and preventative maintenance on PWI Ultra-Lite Systems. It is intended that this checklist be supplemented with any additional instruction sheets and maintenance manuals sent with each job.

The frequency of inspection and lubrication recommendations presented herein is based upon normal operating conditions of one complete handling cycle every 10 minutes throughout a 40-hour week. If the actual duty cycle of a particular unit is greater or less than this, the inspections and lubrications should be performed more frequently or less frequently in proportion.

Each industry has conditions peculiar to it, which may cause wear of certain parts. The tabulation given is only general and may be supplemented by an individual maintenance department program to meet its own particular requirements. Particular attention should be given to corrosive conditions, excessive vibrations, extreme ambient temperature variations, and rough handling conditions.

Questions regarding damaged, worn, or cracked equipment components should be directed to the PWI Inside Sales Department at 574-646-2015.

The recommendations contained herein are to be supplemented by any vendor instructions, which are included in this manual.

WARNING: Power should be off and locked when performing maintenance on any part of the system.

* State and local codes may require inspection and maintenance checks more often. Please check the state and local code manuals in your area.

RUNWAYS & SUPPORT STEEL

ITEM	COMPONENT	MAINTENANCE	FREQUENCY
1	Header-Column Hardware	Check for loose bolts & cracked fittings. Check for full compression of lock washer. Bolt should be tightened to manufacturer's specifications.	Every 1,000 hours or 6 months
2	Header-Runway Hardware	Check for loose bolts & cracked fittings. Check for full compression of lock washer. Bolt should be tightened to manufacturer's specifications.	Every 1,000 hours or 6 months
3	Column Anchoring	Check for loose bolts & cracked fittings.	Every 1,000 hours or 6 months
4	Sway Brace Connection (If used)	Check for loose bolts & cracked fittings.	Every 1,000 hours or 6 months

5	Runway	Check for runway wear or damage.	Every 2,000 hours or yearly
6	Joints	Check for loose or worn hardware or if welded type, for incipient cracks. Check for runway alignment and that wheel rolling surface is flush.	Every 2,000 hours or yearly
7	End Stops	Check for loose bolts and for incipient cracks.	Every 2,000 hours or yearly
8	Paint	Clean periodically and repaint where corrosion is present.	Every 2,000 hours or yearly

BRIDGE

ITEM	COMPONENT	MAINTENANCE	FREQUENCY
1	Controls	Check for burned contacts, broken shading coils, worn or cracked arc barriers, auxiliary contacts, and proper seating.	Every 1,000 hours or 6 months
2	Push Buttons & Pendant	Check contacts. Tighten leads. Check for sticking buttons. Check ground wire continuity. Check pendant cable and bottom for broken wires. Check strain chain to see that any pulling force is not put on pendant cables.	Every 1,000 hours or 6 months
3	Bridge Girder	Check Bridge Girder for wear or damage.	Every 2,000 hours or yearly
4	End Stops	Check for loose bolts and for incipient cracks.	Every 2,000 hours or yearly
5	Paint	Clean periodically and repaint where corrosion is present.	Every 2,000 hours or yearly

END TRUCK, & HOIST TROLLEY

ITEM	COMPONENT	MAINTENANCE	FREQUENCY
1	Structural Frame & Load Bars	Check for incipient cracks in welds and castings. Check for loose bolts.	Every 2,000 hours or yearly
2	Suspension Point	Check for wear and loose or missing screws or pins.	Every 150 hours or 1 month
3	Wheels & Guide Rollers	Check for loose wheel bearings. Check wheels for proper contact and tracking on rail. Check wheel diameter for wear (Replace when 1/4" under original diameter). Check axle nuts for tightness.	Every 500 hours or 3 months

FESTOON ELECTRIFICATION

ITEM	COMPONENT	MAINTENANCE	FREQUENCY
1	Connections	Check connections to ensure no wires are worn and no conductors are exposed.	Every 150 hours or 1 month
2	Insulation	Check to ensure no damage is visible.	Every 2,000 hours or yearly
3	Complete System	In environments that are subject to considerable buildup of dust, especially conductive dust, remove this dust by brushing.	Every 2,000 hours or yearly

STARKE ELECTROTRACK

ITEM	COMPONENT	MAINTENANCE	FREQUENCY
1	Rail	Check for corrosion, bowing, or sagging. Check alignment at moving gaps. Realign if necessary.	Every 2,000 hours or yearly
2	Couplings	Check bolt or screw tightness. Check for corroded contact surfaces.	Every 2,000 hours or yearly
3	Supports	Check for loose bolts and/or screws and bent brackets.	Every 2,000 hours or yearly
4	Insulators	Check for loose bolts, sheared support ears, current carrying deposits on surface.	Every 2,000 hours or yearly
5	Rail Covering	Check for accidental abrasion and peeled covering.	Every 2,000 hours or yearly
6	Current Taps	Check bolt and terminal screw tightness. Check for corroded contact surface.	Every 2,000 hours or yearly
7	Ground	Check for ground continuity. Check at load side of disconnect switch (current off), with meg-ohm tester, for overall system insulation resistance.	Every 2,000 hours or yearly
8	Collectors	Check for worn shoes. Check flexible leads from wheel clevis pigtail or slide shoe shaft. Check tightness of lead connections. Check for cracked insulators. Replace if necessary.	Every 750 hours or 4 months

HOIST (Refer to Hoist Manufacturer)

Notes
