



OWNER'S MANUAL

Gen 2 Wire Rope Hoist

Owner's Manual

3, 5, and 10 Ton Capacity



SMW SERIES



SMW *SERIES*

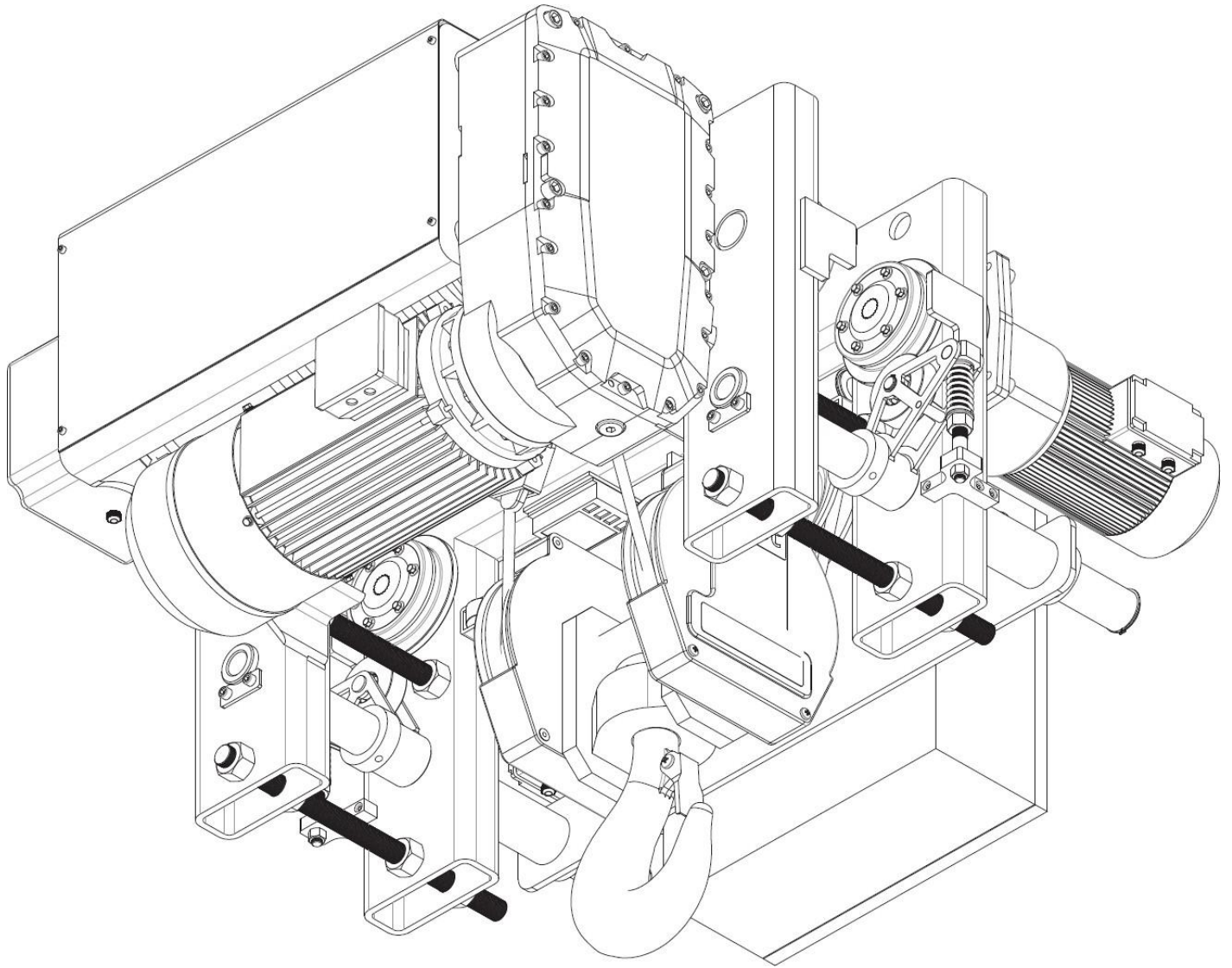



Table Of Contents:	Page:
Product features	4
Forward	5
Safety information	6
General description	7
Typical applications	9
Technical description	12
Lifting motor	13
Transmission gear box	15
Wire rope drum	16
Motorized trolley	19
Hook assembly	22
Electrical & VFD control information	23
Wire rope data	25
Assembly and commissioning	26
Electronic Load Limiter	32
BCQ-HD (W) European Weight Limiter Manual	36-42
Operation manual	45
Inspection and repair	46
Troubleshooting	51
Electrical information & schematics	53
Product information and data	61
Parts diagrams	63
Warranty Information	78

Features



Precision Lift Gearing

The gear box is a three stage oil bath, precision geared, and sealed with cast-aluminum covers, designed for great heat dissipation and easy maintenance. Featuring a two-speed lifting motor with a 6:1 gear ratio for low speed allowing the operator to handle loads with precision, or in high speed for greater efficiency.



Wire Rope Drum and Guide

The rope drum is deeply grooved with high quality seamless steel tube and high tensile rope guide for optimum line arrangement, greater safety factor, and longer life.



Control Panel

High quality NEMA 3S control panel includes phase protection, motor overheating protection, as well as transformer circuit fuse protection. Includes DanFoss VLT Microdrive to control trolley travel speed allowing adjustable smooth ramp-up options.



Overload Protection

For additional safety, this hoist comes standard with built-in overload limiter for both up and down travel operations.



Load Indicator

All models include load cell with small 3/8" LED display for weight and load documentation. Upgrade available to 3" LED display recommended for daily use where weight must be easily visible by operator.



Wire Rope Alignment System

The wire rope aligning arrangement is designed to achieve maximum lifting height and lowest headroom clearance. Utilizing 3 high-strength fasteners at the end of the drum as well as 3 layers of rope for additional safety factor when hook is at lowest level.



4-Part Reeved/Hook Block

Robust all-metal lower hook assembly designed for many years of operation even in tough environments. Includes easy to remove covers for maintenance and wire rope replacement. Hook designed to freely swivel 360 degrees for convenient load attachment.



Pendant Control

Quality pendant control with E-Stop generally used in monorail applications when hoist is not paired with a bridge crane.



Trolley Motor Drive

The trolley travel is operated by two flanged drive wheels mounted on each side of the frame and powered by a single drive motor and pinion shaft that is 2-speed VFD controlled by a Danfoss drive.



Thank you for purchasing the Starke SMW Gen2.0 Hoist.

It is our intention that this document will help address any concerns you may have about the installation, operation, and maintenance of your hoist. The standard hoist comes as a 460VAC / 3 phase unit. Please verify that the power supply you intend to utilize for this system matches the specified power requirements of this hoist system.

Upon receiving your hoist / crane system and its components please securely store all these components in a clean and dry space. Please ensure that all end truck, trolley, and hoist system assemblies and associated electrical panels are all protected from moisture during shipping and storage prior to and during installation. Following these instructions will help ensure a successful installation of the system and maximize your productivity going forward.

Thank You,
Starke America.

!!! IMPORTANT INFORMATION !!!

Please read, understand, and follow all aspects of this manual before the assembly and installation of this hoist system. Please observe and follow all safety and warning information during the operation of this system. Failure to do so may result in serious property damage, personal injury and/or loss of life.

Safety Precautions:

Because of the heavy loads being transported by this system, the operator and those around the serviceable area must be attentive to and aware of all potential risks involved with the operation of this system. The operator must pay careful attention to and abide by the safety rules and warnings listed below and found throughout this manual. **All Safety Rules and Warnings must be followed.**

Warnings:

1. Before operation, the operator must have a clear and unobstructed view of the entire service area of this system.
2. For your safety **DO NOT** attach the electrical supply wires to this unit before the completion of installation!
3. Before operation, inspect the hoist system to be sure it is in proper working condition. Check for any possible obstacles and/or personnel in the service area of the hoist system.
4. While operating the hoist system, the operator must take caution to prevent a situation where the changing of direction of travel and the resulting abrupt force may cause the load to swing. This may cause an overload of the trolley and/or hoist and loss of the load.
5. **DO NOT** modify this unit in **ANY** way or operate the unit in an **OVERLOADED OR DAMAGED CONDITION**. Any attempt to do so will put you, others, and property at serious risk.
6. Repairs to this unit must be performed by qualified repair facility. Contact Starke America to locate the nearest repair facility. See warranty information at the end of this manual.

1. General Description

1.1 User Manual

All relevant personnel should carefully read this document to fully understand the installation, commissioning, and operation of this hoist system. It is advisable to have a copy of this document available to the operator for quick reference during day to day use of this system. This hoist system is a tool for lifting and transporting loads within the workspace which can present many dangers to personnel and property within that space. Please be sure to follow all safety practices and procedures to maintain a safe working environment.

1.2 Operational Limits

Starke hoists are made for various applications and are under an M5 working classification. Upon customer request, Starke can design a M4, M6, M7 classification. This hoist system is used for vertical lifting and horizontal logistical movement of materials. The safe working limits (SWL) shall be listed in the documentation and clearly labeled on the nameplate of this device. This hoist can be installed on a fixed position or movable bridge. The structural design of either must fully comply with all necessary codes and requirements and meet or exceed the specifications for this device listed herein. This hoist is designed for indoor operation in a non-corrosive atmosphere with a nominal temperature of -10 to 40 C (14 to 104 F). Temperatures above the higher limit may reduce the operational lifespan of this device. This hoist is not intended to be used where temperatures exceed 80 C (176 F). Please consult your dealer prior to using this system outside of standard parameters as it may affect warranty coverage.

Starke wire rope hoists are fit for the lifting and carrying of loads subject to the maximum load capacity, FEM group and load group for which it was designed. Load capacity, FEM group and load group are indicated in the data sheet or test booklet of each hoist.

Abnormal conditions are included but not limited to the following:

- Safe Working Limits (SWL) exceeded.
- Oblique lifting of loads

- Lifting or transporting personnel
- Erratic operation caused by improper use of controls.
- Operating hoist with worn or damaged wire rope, broken stocks, or mechanical/electrical damage
- Deliberate tampering / triggering of safety limits

1.3 Operational Specifications

The design, manufacture and operation of this device is in accordance with current CEN and ISO standards.

1.4 Warranty

Starke will assume no liability for any damage(s) to the crane and/or hoist system, property or personnel resulting from improper installation, operation, maintenance by unauthorized personnel for claims by third parties.

Caution:

If modifications to any of the components comprising this hoist system are made by any party other than Starke, or their authorized agent, will invalidate the warranty and any liability obligations thereof for this hoist system.

For safe, reliable operation and maintenance of this wire rope hoist only Starke replacement parts should be utilized. Please contact your dealer or Starke for assistance with obtaining service items for this hoist system.

Safe operation is only possible within the service life stated when the crane and hoist system are installed correctly and operated / maintained properly. Information on wire rope service life is specified in the appropriate sections of this manual. It is strongly recommended this hoist system be maintained and repaired by properly qualified, trained, and authorized personnel. Please contact your dealer or Starke for assistance.

Items to be completed by authorized and certified crane technician before operation of this system:

1. Complete pre-use inspection before placing system into operation.
2. Calibration of upper and lower limit controls.

3. Verification of weight limiter calibration is required during pre-use inspection.

Other Notes:

The declaration of conformity is included in the test book as well as the date of manufacture of the hoist system.

This product will only continue to perform properly if it is operated, maintained, and repaired by personnel qualified to these tasks. Such personnel must be trained in the installation, operation, maintenance, safety regulations, and accident prevention procedures.

2. Typical Applications

2.1 Applications

Starke electric wire rope hoists may be installed on overhead “I” shaped steel rails (straight or curved). They are widely used in plants, mining, railway, port, warehouse, good yards, and service industries. Electric wire rope hoists improve productivity.

Starke electric wire rope hoists are used for:

- Simple cargo lifting
- Equipment installation
- Finished product handling.
- Loading and unloading parts in plants
- Production lines
- Construction Areas
- Lifting hot loads and liquid loads providing working classification is met.

2.2 Operational Conditions

Starke electric wire rope hoists are suitable to work in environments below an elevation of 3280 ft, temperature ranges 14°F - 104°F, and a humidity level less

than or equal to 85%. These environments should also be free of fire and explosion risks, corrosion, and dust.

Note

Lifting toxic, inflammable, or explosive goods is prohibited.

2.3 Power Supply

The standard power supply is 460/3/60 Vac, the ampacity requirements will vary by system design. See electrical information section below or consult your dealer or Starke America if any further assistance is needed.

2.4 Safe Working Time

The load spectrum is as bellow:

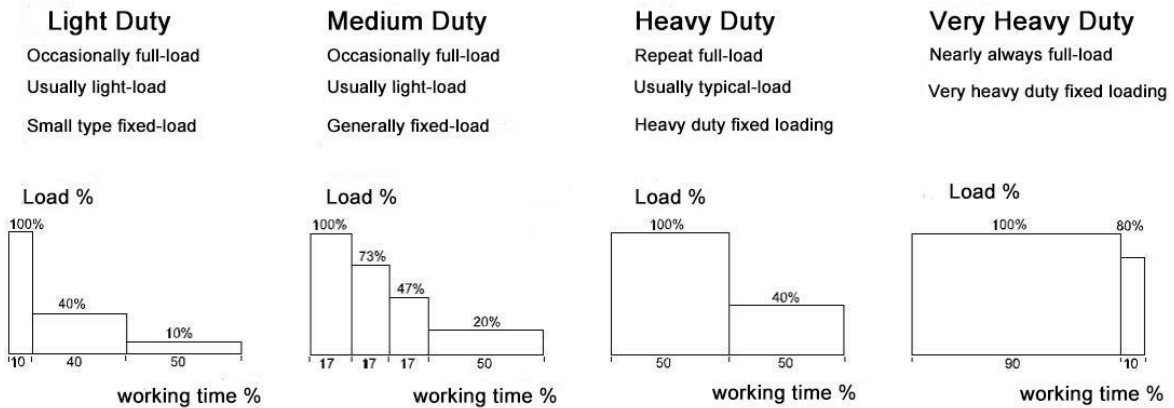

FEM has relevant standards about hoist accidents caused by material fatigue and aging. The following form is referred to during designing of hoists.

Usage period		Work duty FEM (ISO)				
		1Bm(M3)	1Am(M4)	2m(M5)	3m(M6)	4m(M7)
Load spectrum	Light	3200	6300	12500	25000	50000
	Medium	1600	3200	6300	12500	25000
	heavy	800	1600	3200	6300	12500
	Very heavy	400	800	1600	3200	6300

2.4.1 Estimation of safe working time

Experienced service technicians should routinely check and record the service condition of wire rope hoist, then estimate the remaining safe working time according to accepted standard.

2.4.2 Solution for limited safe working time

1. Suspend use of hoist system
2. If continued use is required qualified professional personnel should include the following:
 - a. Qualified professional confirms safety of hoist system.
 - b. Provide inspection records and reports of hoist system.
 - c. Owner accepts responsibility for liabilities of operation past recommended safe usage life.

3. Technical descriptions.

3.1 Structure and components

3.1.1 Components of wire rope hoist

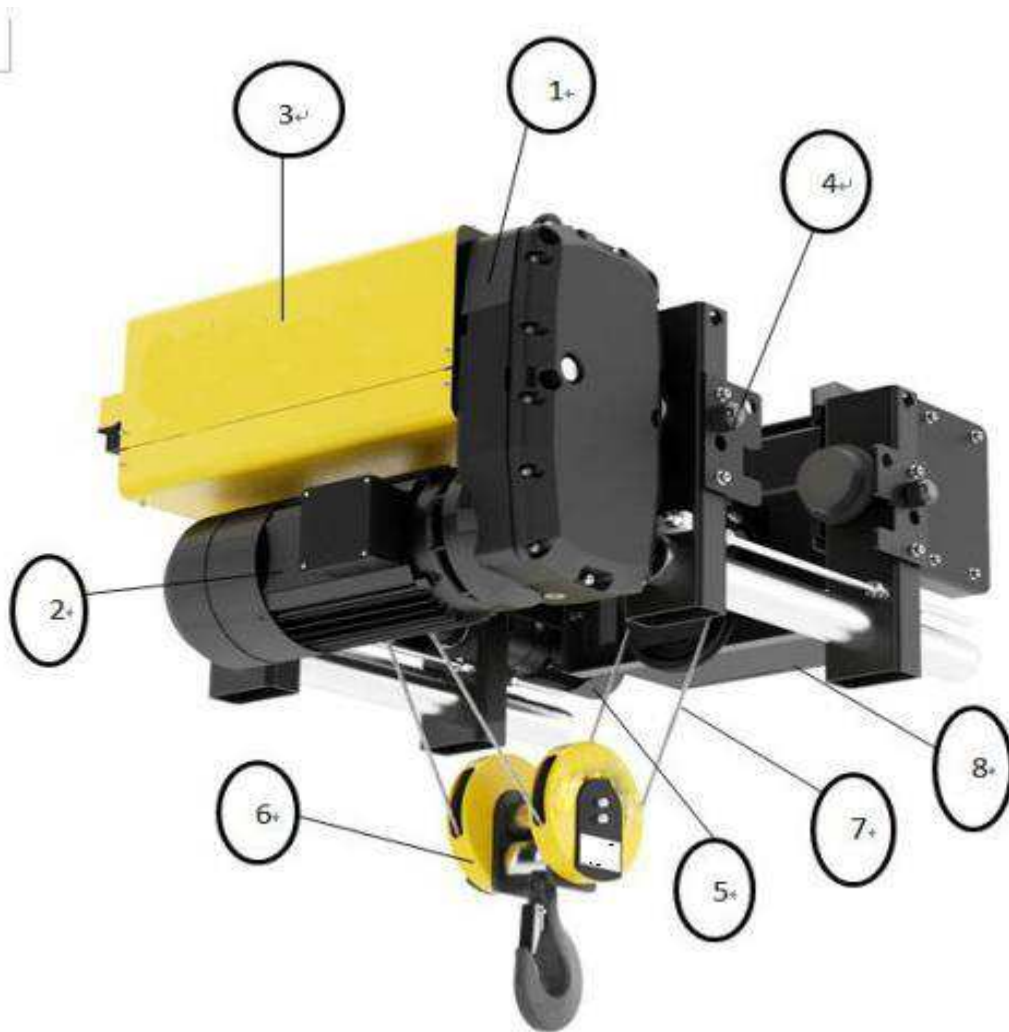

1. Hoist transmission 2. Lifting motor 3. Drum 4. Trolley frame 5.
Trolley traveling mechanism 6. Hook 7. Wire rope 8. Control cabinet

3.1.2 Lifting Motor

The standard lifting motor is a two-speed motor with electromagnetic disc brake. A variable speed motor is optional and has electromagnetic brake.

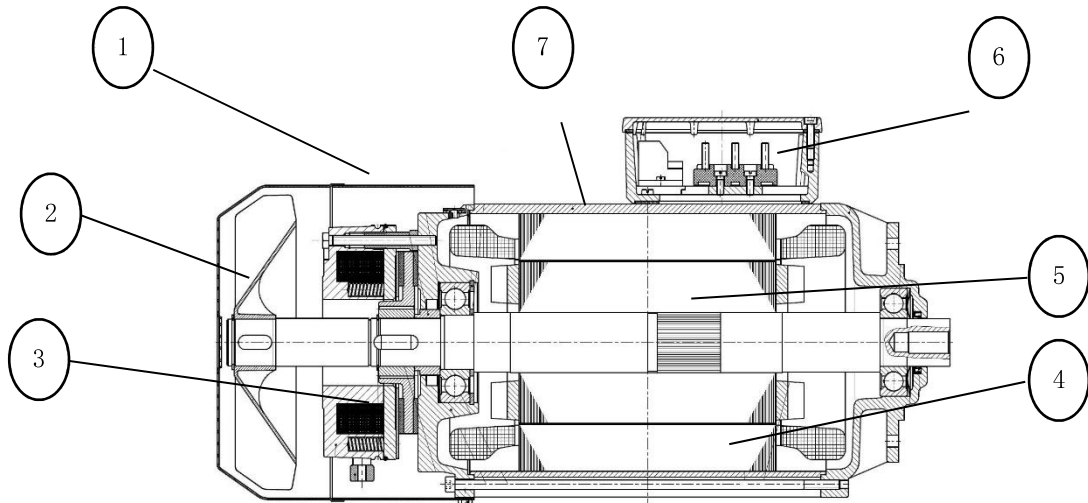

1. Fan Cover 2. Fan 3. Brake pack 4. Stator 5. Rotor 6. Junction box 7. Motor Frame

Two-speed (variable-frequency) motor has (three) thermostats or sensors. The windings of the motor are class F rated. When the temperature is above 150 °C, thermostats or sensors will remove power from motor until temperature has lowered to safe operational level, the motor will then be allowed to operate. The maximum operational temperature of this hoist system is 40°C

The lifting motor has an integrated electromagnetic disc brake (see figure below). When the hoist lifting motor is in the stop or de-energized state the electromagnetic disc brake will be engaged.

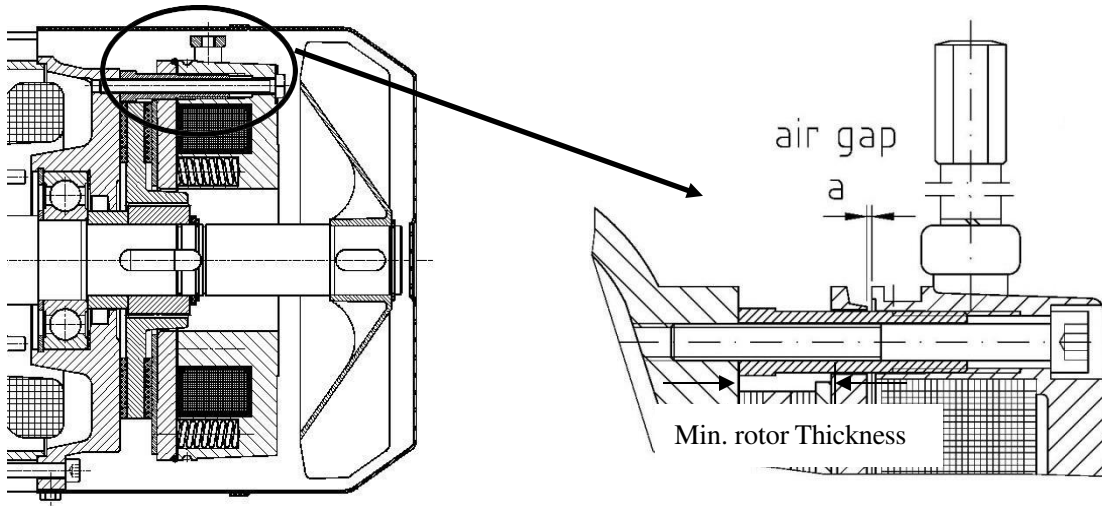

The IP grade of standard electromagnetic disc brake is IP54, the highest IP grade can be up to IP56. Meanwhile, electromagnetic disc brake can alternatively install manual release lever. The brake uses dust-proof design, which doesn't need other maintenance during normal operation.

Attention!

It is imperative to check brake clearances on a regular basis.

Specific reference values and adjustments are as below.

type	08	10	13	15	17	20	23	26	30
normal gap	0.2	0.2	0.3	0.3	0.3	0.4	0.4	0.5	0.5
maximum gap	0.6	0.7	0.8	0.9	1.0	1.1	1.1	1.2	1.2
minimum thickness of brake disc	4.5	5.5	7.5	9.5	11.5	12.5	14.5	16.5	16.5

Attention!

Checking and adjustment of brake components are to be done by qualified professional maintenance personnel. During this period, the hoist must be under no-load, and the main power must be locked out.

3.1.3 Hoist transmission gearbox

The wire rope drum is driven by the lifting motor via the gearbox. The output shaft has been designed with a volute spline to achieve optimal transmission reliability.

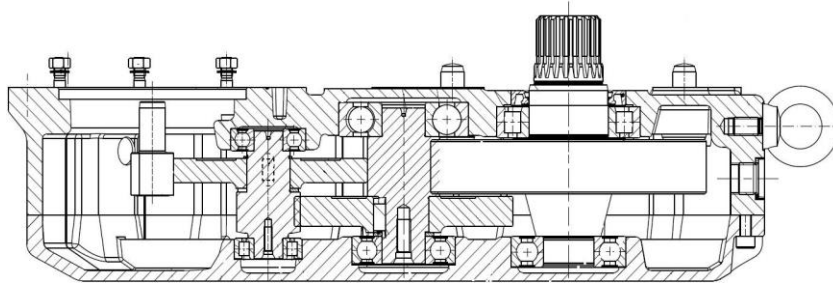

For optimal performance and longevity of the gearbox please strictly follow FEM recommendations, and with the use of high quality lubricants no other maintenance during safe working time should be required under normal use conditions. The gearbox has been filled with lubricant prior to shipment. Please observe the type and quantity of lubricants listed in the chart below. Please be sure the cover of gearbox is absolutely clean to prevent contamination during the addition or changing of lubricants.

If hoist is used in frigid environment, the lubrication oil must be changed to synthetic grease.

Time	Working content	Model of gearbox	Viscosity of lubrication oil	Volume of lubrication oil
Every six months or up to 3000 hours	State of lubrication oil	GH3201	VG680	1400
		GH5000A	VG220	4000
Every three years (operation under FEM)	Change lubrication oil (if it is mineral oil)	GH12500	VG680	5000
		GH20000	VG680	9000
Every five years (operation under FEM)	Change lubrication oil (if it is synthetic grease)	GH25000	VG220	13000
		GH40000	VG220	15000

If hoist system is utilized in a harsh environment, it is important to perform maintenance inspections more frequently, these environmental conditions may include:

- Extreme moisture
- Dust
- Caustic or corrosive elements
- Wide temperature variations

3.1.4 Drum

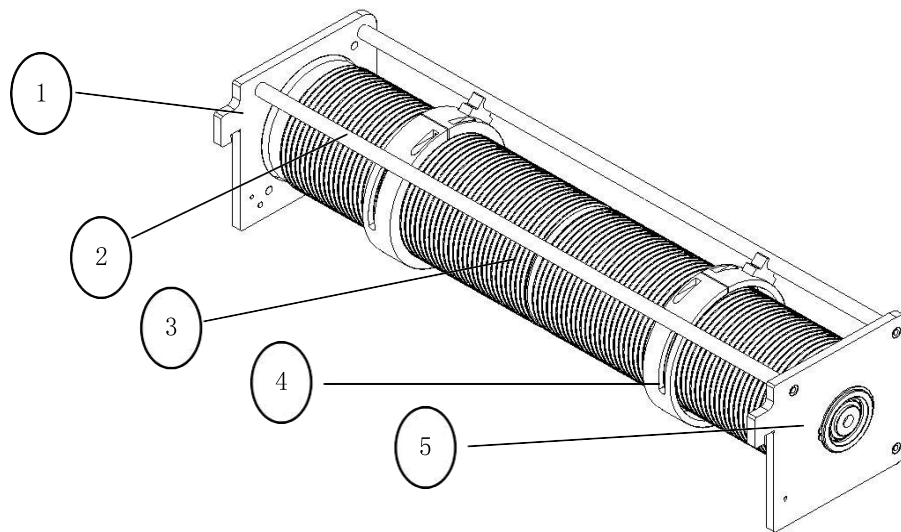

1. Left end plate 2. Rope guide rod 3. Drum 4. Rope guide 5. Right end plate

The drum is manufactured from seamless tube, and the surface is machined into rope races according to different model requirements, such as right-handed rotation or left-and-right handed rotation. Both ends of drum are flanged.

The drum has a rope guide which is constructed with a wearable engineered plastic inside which provides rope guidance into the races of the drum. It is split into two halves, and installed around cylinder with a nut, washer, and spring. Upon installation of the guide(s) assembly care should be taken to not overtighten bolts as the guide will need to float above wire rope slightly. The rope

guide will traverse along the guide rod as wire rope is paid out or retracted to maintain proper winding of wire rope on the drum. In addition, the rope guide can also trigger an alternative limit device.

On some models with dual wire ropes, you will have two guides installed correspondingly.

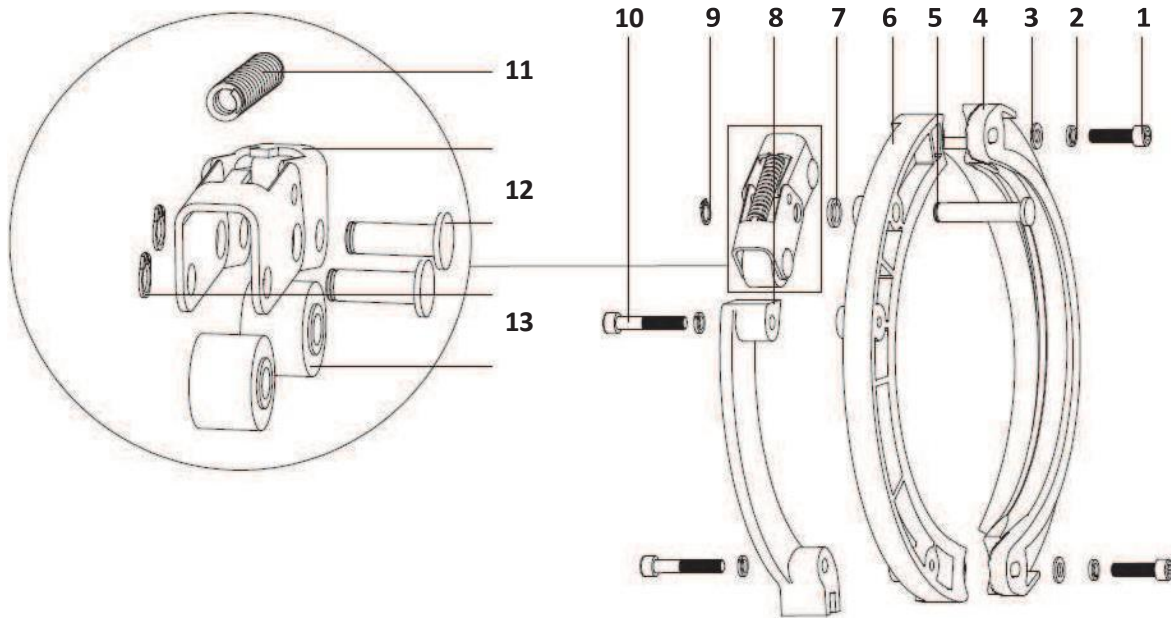

1	Hex Bolt	6	Rope Guide Ring B	11	Clamping Roller Spring
2	Spring Washer	7	Washer	12	Clamping Roller Frame
3	Washer	8	Rope Guide C	13	Clamping Roller Pin B
4	Rope Guide Ring A	9	Snap Ring	14	Snap Ring
5	Clamping Roller Pin A	10	Hex Bolt	15	Clamping Roller

Winding methods include single winding and double winding. In the illustration below note the clamps used to secure wire rope to the drum. If the drum is double wound, you will have the same clamps on the opposite end. Industry standard requires that when the lifting hook is at its lowest design position in relation to the floor that two complete wraps of wire rope encircle the drum in addition to the length under clamps. This would apply to each end if the drum were a double wrap design.

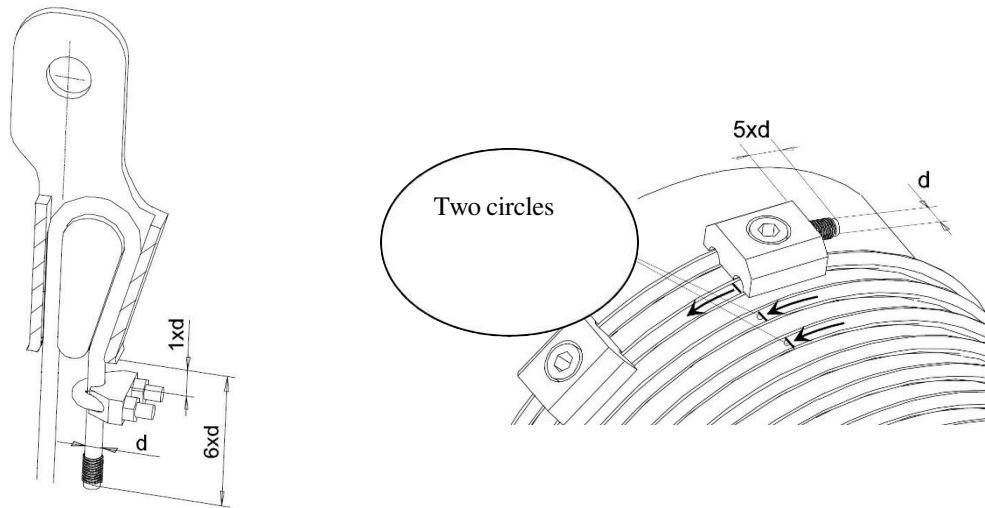

3.1.4.1 Upper and Lower Limits

The Starke wire rope hoist uses a screw type cam limit switch, which is installed on side plate of drum making it convenient for precise adjustment. The switch has two separate contacts to allow the hoist to slow down upon tripping the first limit and safely stop upon tripping the second limit providing safe load handling.

3.1.5 Trolley Frame

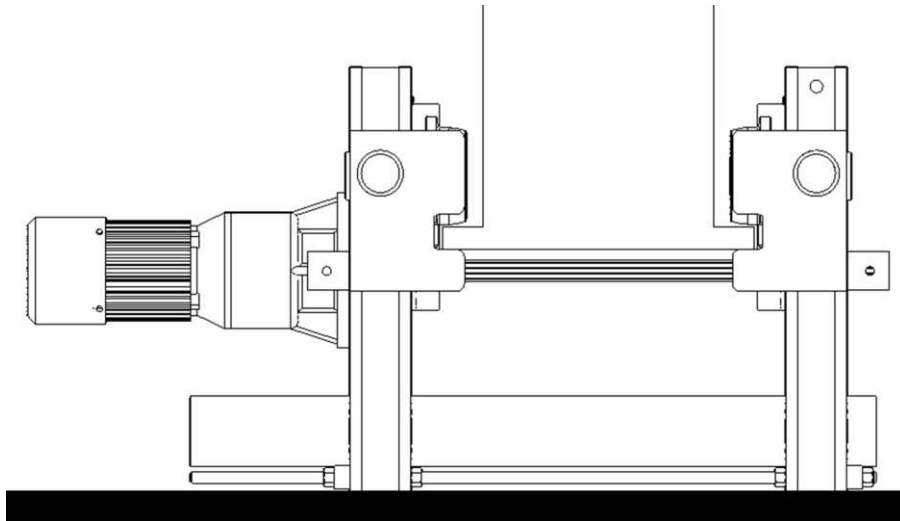

The trolley frame of double-girder hoist is constituted of connecting girder and end beams. Fixed pulleys and overload limiter are installed inside the connecting girder. The size of trolley frame depends on load, lifting height and some other elements of system design.

3.1.5.1 Overload Limits

The overload limiter will stop the hoist from lifting if the actual load is over the rated capacity. Load protection is provided by an electronic load cell. The overload limiter's installation for single wind vs double wind is as below:

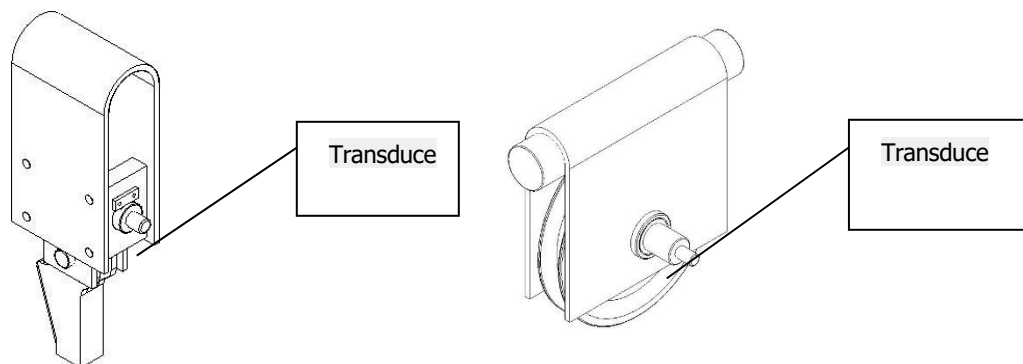

Attention

The overload limiter has been calibrated in the factory with rated load. When performing overload test on site, please disable overload limiter. After completion of testing be sure to enable the limiter.

If the set point value of overload limiter is marginally different and needs recalibrated, please contact hoist manufacturer or professional maintenance personnel to reset overload limiter.

3.1.6 Motorized Trolley

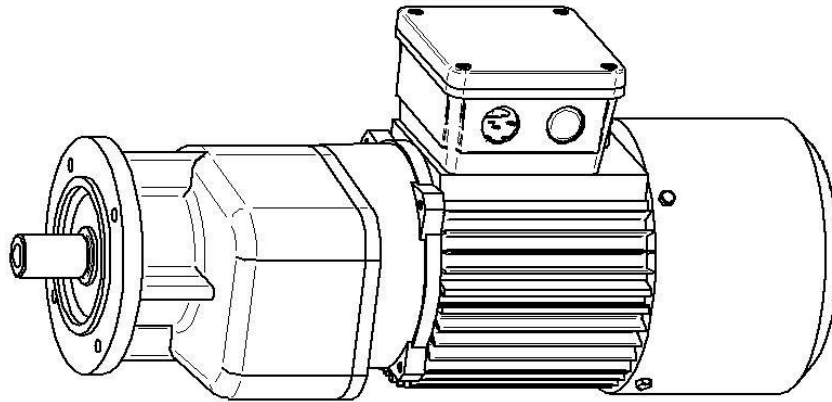

Motorized trolley includes squirrel-cage motor and gearbox. The motor is rated for variable frequency drive operation with IP54 rating and has internal high temperature limit switches. The motor is also provided with an electromagnetic brake pack. The trolley motor is designed and manufactured according to VDE0530, which can endure 1.5 times of rated current for two minutes without damage to motor windings.

The helical gearbox with parallel axle provides improved transmission efficiency and reduces operational noise. Under normal operation the gearbox is virtually maintenance free.

3.1.7 Wire Rope

Wire rope is the main stressed part as well as the most vulnerable part of hoist system. To make sure safe operation is maintained, operators should strictly follow safety operation manual. Client should also frequently check and maintain wire rope.

Routine maintenance includes but not limited to:

- Visual inspection
- Excessive dirty grease removal
- Check transmission lubrication and wear.
- Check for broken wire strands.
- Check for corrosion of wire rope.
- Check connectors and rope guides.
- Clean and lubricate (see attachment of Lubrication)

The inspection and scraping standard refer to ISO 4309:1990. For relevant data see the attachment.

Attention!

It is very important to frequently inspect and maintain wire rope. Please immediately cease operation and remove load as soon as any abnormal issues of the wire rope are discovered. Contact qualified service/maintenance personnel to inspect and/or replace wire rope if necessary.

3.1.8 Hook Assembly

Hook assembly usually made up by following components:

- Hook forging
- Overhang card
- Hook beam
- Hanger plate
- Pulley assembly

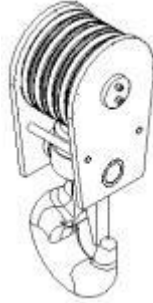

The hook is the main stressed part of the hoist. The daily inspection and maintenance of hook includes but not limited to the following:

- Damage of hook forging and overhand card
- Free rotation of hook
- Wearing of pulleys
- If cover of pulley rubs wire rope

Perform required maintenance according to inspection results, such as changing wearing parts or adding lubrication oil (see attachment for lubrication).

3.1.9 Hoist Electrical Controls

Power supply requirements for Starke standard wire rope hoists are 460/3/60Hz and drive power is 24V/1/60Hz. The configuration for a standard wire rope hoist and trolley is two speeds, contact your dealer for optional configuration. Our Gen 2.0 hoist systems are now utilizing Danfoss variable frequency drives as standard equipment driving the trolley motor.



Cautionary Note!

After disconnecting main power, there is still a **high voltage** potential within the filter capacitors, please allow adequate time for this voltage to dissipate before performing any maintenance work on the VFD inverter. Please wait until the charge led is off and bus voltage is under 36V. The Danfoss VLT Micro Drive documentation is included within the information packet for hoist system, please refer to this manual for specific warnings and procedures in maintaining the VFD.

Due to the temperature, humidity, dust, and vibration the components of the control system will be operating in it is recommended to perform the daily and periodical maintenance. Items needing to be checked are, but not limited to, as follows:

- Observing abnormal change in motor sound during operation.
- Excessive vibration during motor operation.
- Motors stall during operation.
- VFD cooling fan is working properly.
- Control cabinet overheating.
- All electrical terminations are properly secured and torqued.

Keep VFD fan and heatsink clean and remove dust build up with in control cabinet with gentle application of compressed air. Use caution if metallic dust is on the surfaces to avoid depositing it within control cabinet and its components. If the cooling fan blades are clogged with oil impregnated dust and/or heat sink fins occluded, may require removal of the VFD(s) for proper cleaning. Refer to Danfoss manual for these procedures and should only be performed by a qualified technician.

3.2 Wire Rope Data

Diameter	minimum breaking force	strength grade	Extruded rope	weight
6	33.34 kN	2160 N/m m ²	yes	0.17 kg/m
8	58.84 kN	2160 N/m m ²	yes	0.283 kg/m
11	111.8 kN	2160 N/m m ²	yes	0.54 kg/m
15	207.9 kN	2160 N/m m ²	yes	1.02 kg/m

3.3 Lubrication Information

Gearboxes and bearings have lubricants installed before delivery and under normal circumstances are within safe operational working levels. It is good practice to verify levels and add lubricant if needed prior to putting the hoist system into operation.

Recommended lubricants are:

- Shell Super ATF
- DEA 5060
- ESSO ATF D 21611

Note: Synthetic lubricants should not be mixed with mineral lubricants.

4.0 Assembly and Commissioning

Please read all installation and operating manuals as well as the relevant safety regulations carefully before hoist installation and commissioning.

Unless stated otherwise, the standard shipping status for hoist rope and hook have been assembled, the wheelbase or rail gauge wheels are manufactured and adjusted to the position in accordance with the order. Electrical parts have been functionally tested at the factory but lifting height and weight limits are required to adjusted on site at time of installation.

If the wire rope hoist is not to be installed immediately it must be stored in a dry and clean place.

4.1 Preparation for assembly

Before beginning assembly, please confirm the following are available:

- Properly qualified and trained personnel (quantity and skills)
- All required tools and rigging systems to install properly and safely.
- Adequate time to safely and properly commission system and document

4.2 Hoist lifting

4.2.1 Single girder hoists

The width between the single girder flange and trolley wheels (B1) has been adjusted before delivery. The dimension of B1 must be 4~5mm bigger than bottom width of support beam flange. Before assembly, please confirm the dimensions of B and B1. If the real dimension of B is different from the order and needs to be adjusted B1, please contact your dealer.

- Loosen the nuts (1 and 3), and lock piece 2
- Lift the hoist on to the support beam.
- Adjust the size and dimension of B1 (about 5mm bigger than bottom width of support beam flange)
- Pre-tighten the lock nuts (1 and 3), check that all the wheels are running true and parallel, adjust the lock nuts if necessary.
- Tighten the lock nuts.

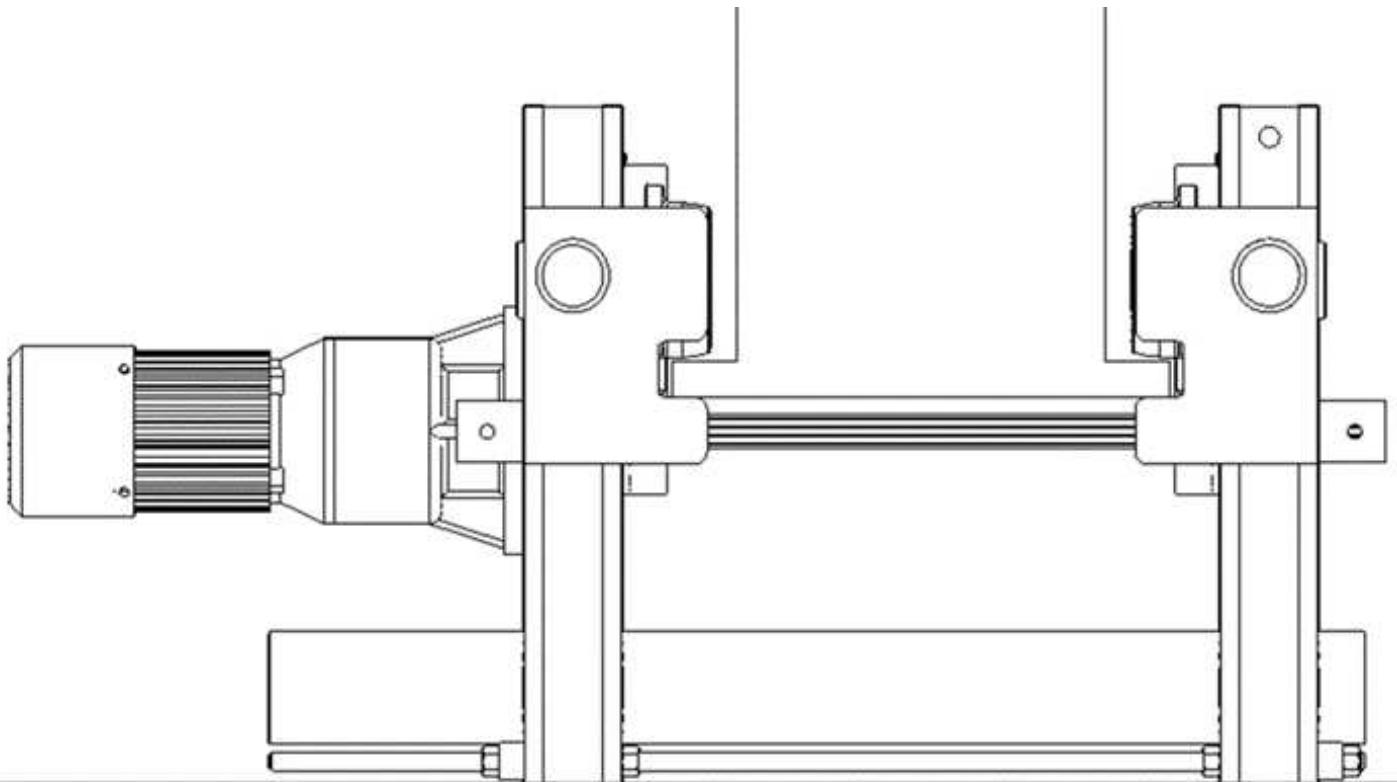

Double girder hoists

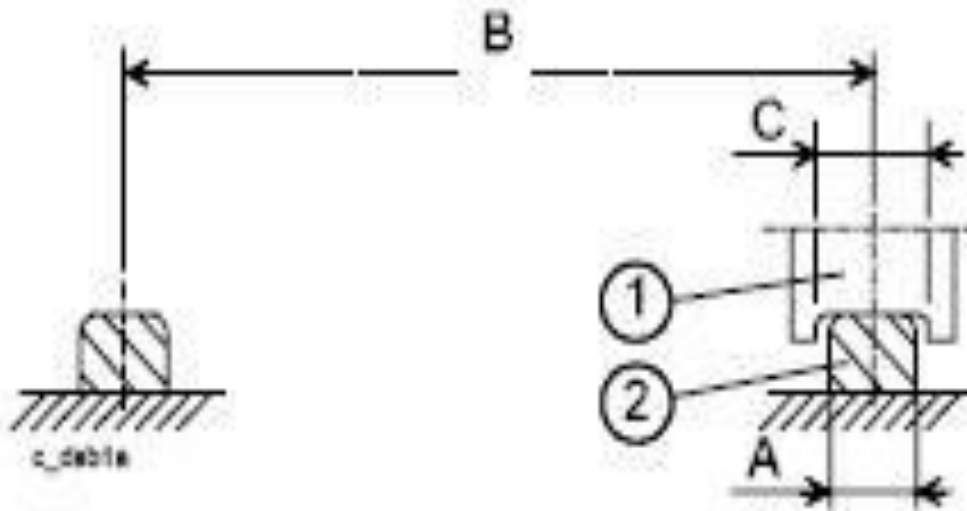

- Check the hoist wheel groove width (C) and rail tread width (A), the standard dimension is $C=A+15\text{mm}$
- Check whether the support beam rail center distance (B) is consistent with the hoist gauge R. Standard dimension is $B = R \pm 2\text{mm}$
- Lift the hoist on the support beam and check for proper alignment.

Before assembly, please confirm the dimensions of B and C, which has been adjusted at the factory before delivery. If the actual dimension of (B) is different from the order specifications and needs to be modified (B1), please contact your dealer for assistance.

4.3 System Commissioning

4.3.1 No-load check

4.3.1.1 Electrical system

- Verify voltage and ampacity of the power supply circuit is in accordance with the hoist system specifications. Also verify proper phasing of power supply as hoist system is equipped with a phase monitor system that will prevent hoist from operating if phasing is incorrect. (By others)
- Verify power supply cabling is of the correct capacity ratings for the hoist system. (Supplied by others)
- Verify power disconnect device is in place and sized accordingly (Supplied by others)

According to standard electrical code requirements and best practices, wire rope hoists shall be equipped with the main power disconnect switch. The main power disconnect shall be installed near the main power supply line termination point for the hoist system.

4.3.1.2 Pendant control

Pendant push button controls are one of several options to the configuration of your hoist system.

If pendant is used to control the hoist system, please check the following on regular basis.

- Check that pendant control cable and strain relief attachment points are in good repair. The strain relief cable ends should be adjusted to take the load off control wire cable by tightening strain relief wire and securing with the cable U clamps.
- If equipped, verify audible and visual indicators are functioning properly during system operation.
- If directional indicators on pendant buttons are incorrect, they can be corrected by changing the tags contained inside button cavities.
- Verify the operation of the emergency stop button. Do not press the emergency stop button during normal lifting / traversing operations to stop movement in any event other than an emergency. In normal operation releasing the control button will allow system to safely cease movement. The emergency stop can be used to secure the hoist system when not in service.

4.3.1.3 Noise

In normal use of the hoist system there will be obvious noise created by the operation of the mechanical components that comprise the system. In day to day use operators will learn what “normal” noise is as they become accustomed to the systems in operation.

If excessive vibrations or loud noises become noticeable it is advisable to stop the use of the hoist system and contact appropriate maintenance personnel to determine the cause and resolution of the issue.

Possible causes could include but are not limited to:

- Power supply issue – check voltage is correct, and all phases are present.
- Check trolley wheels and runway for obstruction or damage
- Gearbox lubrication is at proper level and wire rope is sufficiently lubricated.
- Check that wire rope is not rubbing or dragging on any component it has contact with. Also inspect for abrasions and fraying of wire strands

4.3.1.4 Upper and lower limit switch calibration

Check calibration of upper and lower limit switch to prevent damage to hoist system.

This should be done during pre-use inspection and subsequent annual inspections.

4.3.1.5 Travel limit switches

If travel limit switches are provided for the trolley, they should be calibrated to stop trolley before contact with the runway end stops.

4.3.1.6 Hook and sheaves

Inspect the wire rope sheaves and they are freely rotating within hook body.

Check that the hook can rotate freely within its mount.

4.3.1.7 Wire rope

Inspect wire rope and that it has not been damaged during operation.

Visually inspect that wire rope is properly winding on the drum and that rope guides can freely track the coils in the grooves.

Check clamp fasteners on the end(s) of drum are tightened to proper torque specification and wire rope is securely held in place. Two complete wraps of wire rope around the drum in addition to the clamped section are present when lifting hook is at its lowest travel limit.

4.3.1.8 Overload protection

Check calibration of overload system and that it is functional.

Summit Lifting Load Limiter

Controller appearance description

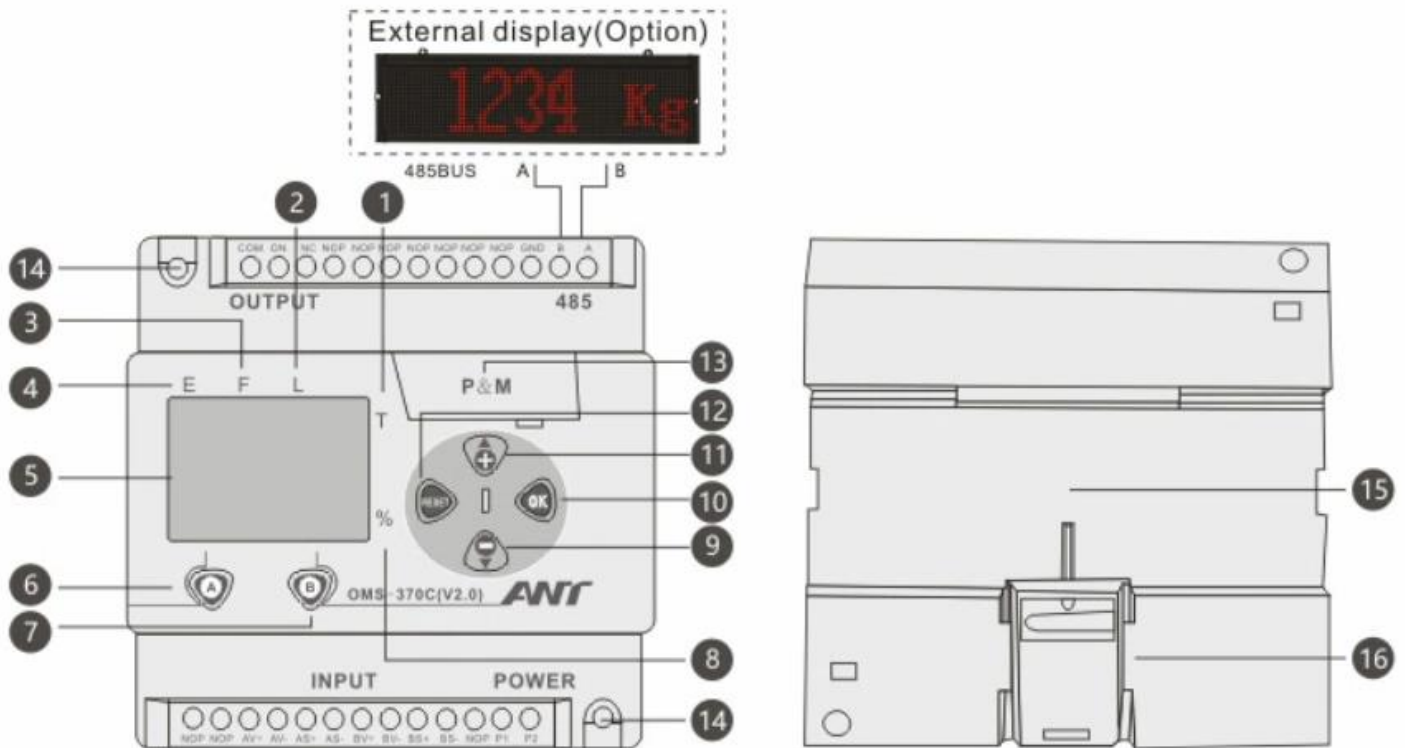

① Load indicator defaulted KG, (Not bright)	⑨ [-] Short press: Data decreasing Long press: Fast decreasing
② Normal indicator	⑩ 【OK】 Confirm
③ Warning indicator	⑪ 【+】 Long press: Data increasing fast Short press: Data increasing
④ Overload indicator	⑫ 【RESET】 Return
⑤ Data displays	⑬ Online programming port
⑥ 【A】 Long press: Clear	⑭ Φ4 Screw the mouth
⑦ 【B】 Long press: Rated load and sheave ratio program Short press: Load and percentage display	⑮ 35mm Rail mounting groove
⑧ Load and percentage indicator	⑯ Rail fixed buckle



Connections

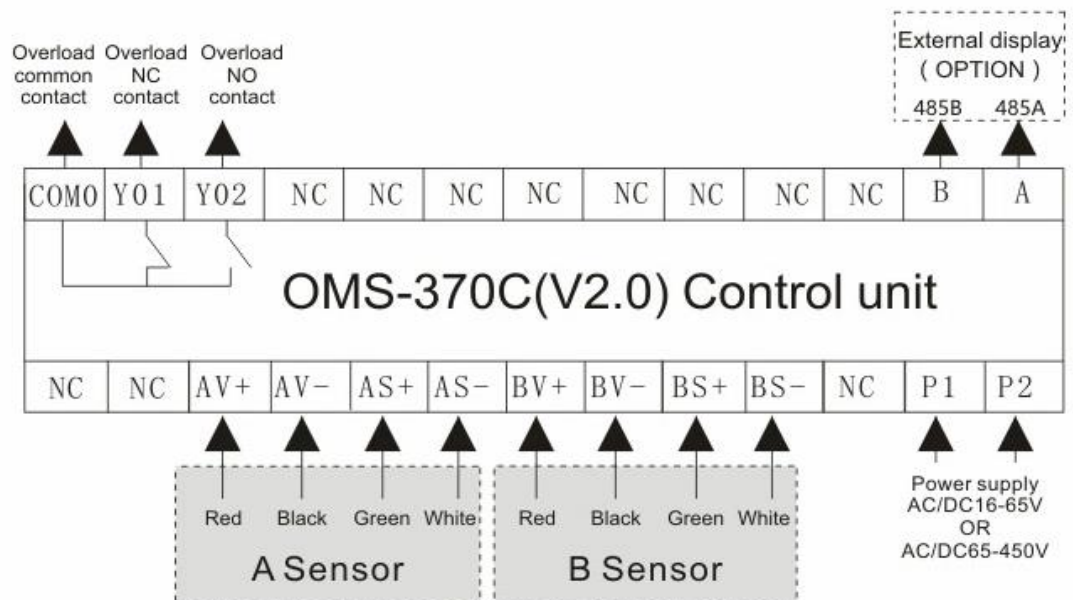

Calibration (Choose one method)

*Remind:

- ① Tare indicator blinks means the absent of tare operation. Alarm indicator blinks means the absent of rated load setting.
- ② To modify the rated load after the calibration, you just need take the step B in the method 2.
- ③ In method 2, the weight used must be more than 50% of rated load. otherwise, the accuracy would be low.

Method 1 : No weight calibration(recommended):

- A. **Tare**→Empty car, long press[A] for 5s, display from **9999** to **0000** till display **Zero** .
- B. **Rated load and roping calibration**→Long press [B] for 5s,it display **FULL** .push **[OK]** push [+] or [-] to input the rated load value. Then push **[OK]** to save data. **roPE** ,push **[OK]** , push [+] or [-] to input roping value. Then push **[OK]** to save data.

Method 2: Know weight calibrations

- A. **Tare**→Empty car, long press[A] for 5s, display from **9999** to **0000** till display **Zero** .
- B. **Rated load calibration**→Long press [B] for 5s,it display **FULL** . push **[OK]** , push [+] or [-] to input the rated load value. push **[OK]** to save data. Then push **[RESET]** to return.
- C. **Known weight**→Put the known weight in the car, long press [+] for 5s, data blinks to indicate the weight(KG). push [+] or [-] to modify the data to real weight, the push **[OK]** , it display from **9999** to **0000** and save data automatically.

Menu functions

Push and release **[OK]** and **[ESC]** at the same time. It displays **CC00**. Push **[+]** or **[-]** till it display **CC11**. Then push **[OK]** into menu options.

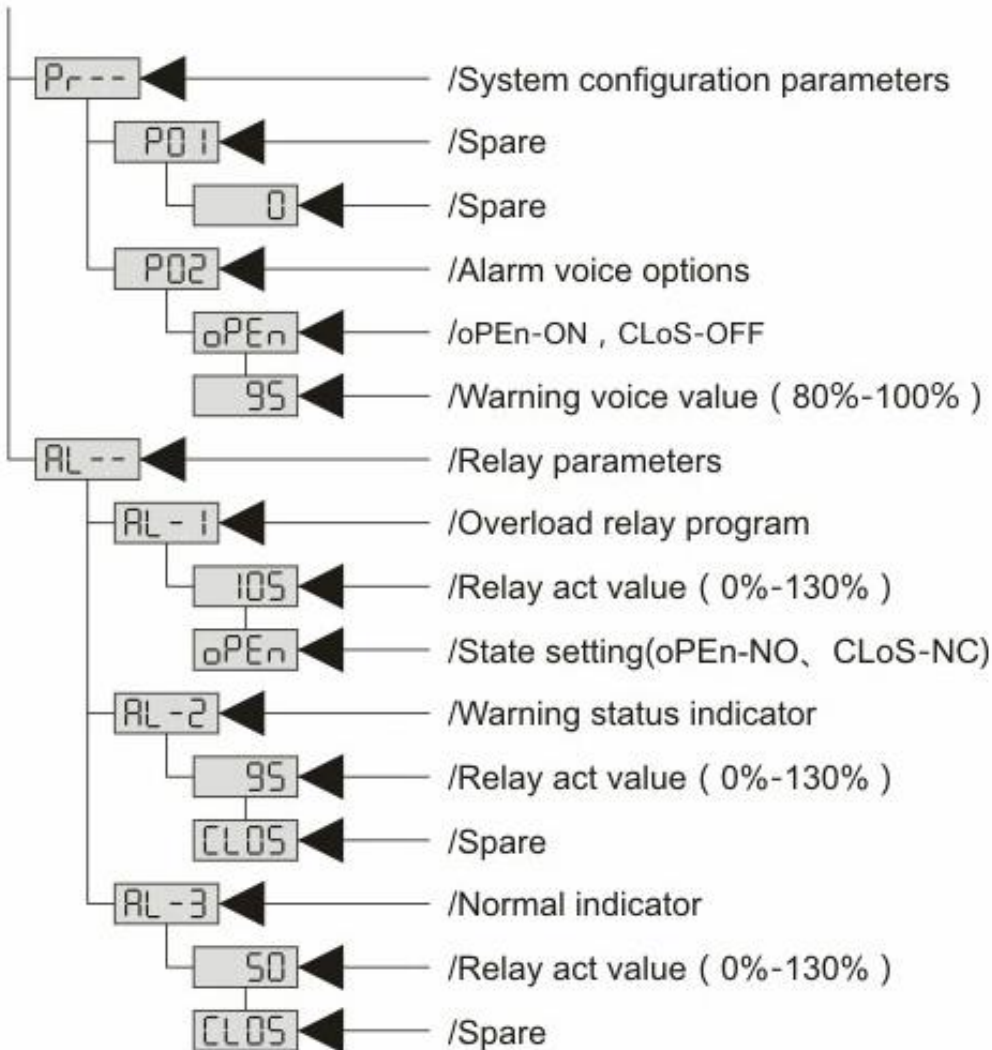

[OK] to next menu step.

[ESC] to return to upper step.

[+] or **[-]** choose data in same level.

Push **[OK]** to save data after calibration

The value 80% means it is 80% of rated load.

Error codes

Codes	Reasons	Solutions
E01	During known weight calibration, there is absent of TARE operation.	Make the cabin to be empty, Long press [A] for 5 seconds to finish TARE operation.
E03	During known weight calibration, the weight is less than 100KG.	Use the weight of more than 50% of rated weight to calibrate.
E05	The load is exceed the load cell MAX.capacity.	Make the load within the load cell capacity or change load cells with bigger capacity

BCQ-HD (W) European Weight Limiter

Instruction Manual

Page 36-42

Please read the instruction manual carefully before using the product.

The hardware drawings, styles and specifications listed in the manual are for reference only. All items are subject to change.

OVERVIEW:

BCQ-HD (W) series hoisting weight limiter is an overload safety protection device mainly used in European single 1 beam and consists of a sensor and instrument. The main technical specification conforms to the requirements of GB/T 12602-2020 Technical specifications for Overload Protection Device of Hoisting Machinery. It not only features a compact structure, but also has detailed user-friendly functions such as zero tracking, one-key clear, system self-check and malfunction indication, 4-20ma output and a large screen or nonstandard control output interfaces are available to suit specific demands.

MAIN TECHNICAL SPECIFICATIONS:

1. Scope of application: 0.5t~631 various European hoisting machines with single or dual beams
2. Synthesis deviation: $<\pm 5\%$ F.S.
3. Action deviation: $<\pm 3\%$ F.S.
4. Sensor overload headroom 150%
5. Operating ambient condition: Working temperature $-20\sim+60^{\circ}\text{C}$ Relative humidity 90% RH
6. Power supply voltage: AC 100~500V
 - a. Please indicate on the purchase order if you need another power supply voltage (AC/DC 16-65V)
7. Alarm:
 - a. Warning Alarm: 90% of rated weight
 - b. Delay Alarm: 105% of rated weight (after continuous overload time of 2 seconds the relay will activate)
 - c. Immediate Alarm: 110% of rated weight
8. Capacity of relay contactor: 7A/250VAC
9. Protection grade of sensor: IP65
10. Display mode: 6-digit LED digital display

PRINCIPLE OF OPERATION:

When the hoist lifts heavy weights, the sensor will output an electric signal which is in proportion with this load. This signal will be converted to a digital one and then enters the main control CPU which will process it and display the real-time weight.

When the lifted weight reaches 90% of the set point, the instrument will output a warning signal, the yellow light flickers without activating the relay.

When the lifted weight reaches 105% of the set point, both yellow and red lights will flicker, control relay will delay 1-2 seconds before activating and the buzzer will alarm at the same time.

When the lifted weight reaches 110% of the rated load set point, the control relay will open immediately and activate sound and light alarms.

INSTALLATION AND ADJUSTMENT:

Precautions:

1. Please check if this product model is of appropriate capacity for your lifting equipment before installation.
2. Each time after starting up, press the self-test key to check whether the device is working normally.
3. The power supply of this product should be continuous if the main power disconnect is on.
4. This device is not intended for wet/corrosive environments, all precautions should be taken to protect it.

INSTRUMENT INSTALLATION:

The instrument can be installed inside the electric control cabinet. Proper anti-vibration measures should be taken if the vibration of the hoisting machine is too strong. Do not install the instrument in a wet location with direct rain and/or strong corrosive environment.

WIRING:

Connect the power supply cord: Connect two power leads to the power supply (the wiring should be correctly connected according to the label and pay attention to the supply voltage).

Connect the control wire: The control output of this product is a normally closed, dry contact relay. When connecting, the control is wired in series with the control circuit of the lifting motor **UP** contactor of the hoist. In case of alarm due to overload condition, the control relay will open, and the lifting motor **UP** contactor will be de-energized to achieve the protection.

Connect the signal wires: The sensor of the control instrument is connected via the aviation style connector located on the top of the control box, insert and tighten the captive ring nut.

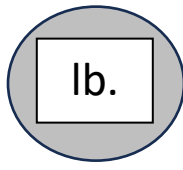
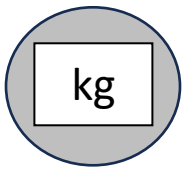

BCQ-HD (W) European Weight Limiter

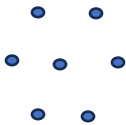
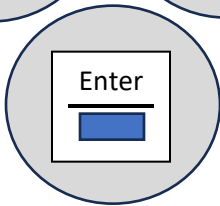
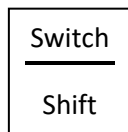
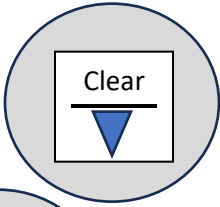
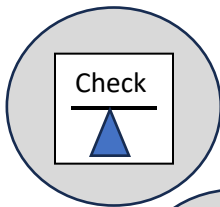
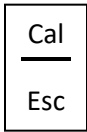
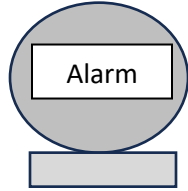

ADJUSTMENTS AND USAGE:

1. KEYBOARD INSTRUCTIONS:

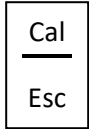

Calibration Button: Press this button to enter the calibration function. It also has the function of Escape.

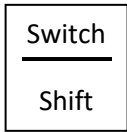

Switch/Shift Button: Press this button to switch the weight display unit kg or lb, and the corresponding indicator light will be on with Shift function.

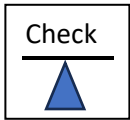

Check Button: Press this button to check if the system of the instrument functions properly. It also is used to increase value.

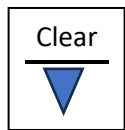

Clear Button: Clear manually by long pressing (remove the gross weight). It also is used to decrease value.

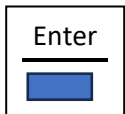

Enter Button: Press this button to save the parameters you set. Under the measuring interface, press the button to perform the functions. A short “beep” sound will be heard when the operation is effective.

2. DISPLAY INSTRUCTIONS:

- a. START UP DISPLAY: “U1.01” displays the software version
- b. MEASURING INTERFACE: ***** Displays the current weight.
- c. CHECK INTERFACE: **** Displays the overload set point weight. The red and yellow lights flashing.
- d. SAMPLING VOLTAGE INTERFACE: **. ** Displays the current sensor reference voltage – the figure flashes.
- e. CALIBRATION INTERFACE: ***** One of the figures flashing.
- f. PASSWORD INPUT INTERFACE: ----- is displayed, one of which flashes and “1111” is required to enter the calibration interface.

3. METHODS OF ADJUSTMENT:

- a. CLEAR: For initial installation, due to the inconsistent weights of reel and steel cable, the instrument will display a value or display "0", press the CLEAR button when no load is present. Long press the CLEAR button for over 3 seconds. When you hear the "beep" the instrument will display "0", then release the CLEAR button which means the clearing operation is completed.
- b. CALIBRATION:
 - i. The instrument has been calibrated in the factory. Normally the users can skip this step. If the deviation is too large due to on-site mechanical installation etc., you can calibrate it.
 - ii. For initial calibration, input the password "1111". You will hear three short "beeps" and you will see "Err" if the password is incorrect. The calibration must be finished within 5 minutes after the correct password is input. If you fail within the time limit, the password must be re-inputted (the double underlines below mean flickering display).
 - iii. In Calibration Mode: Press the CAL button, it shows ----- then you can input the password. Use ▲ and "SHIFT" button to input "1111". Press "ENTER" button to enter the calibration mode, it will display ***** , the figure displayed is the current weight. Press CAL button again to enter the calibration mode directly within 5 minutes after the correct password is input)
 - iv. To calibrate use a calibration weight that is more than ½ of the rated weight capacity, lift the calibration weight and enter its known value weight by pressing "SHIFT" + ▲ + ▼ buttons. Then press the ENTER button to save calibration parameters. Then go back to the measuring interface ***** and verify the calibration is complete.

ATTENTION: For a new initial installation, you must perform a clear operation which can only be done when no load is on the sensor.

When the hoist is lifting 90%-105% of the rated weight, the instrument enters the warning state, the yellow light will flicker but will not cut off the up-control circuit. It reminds you that the hoist is almost fully loaded.

If you wish to test the hoisting machine's overload ability, it is possible to bypass the circuit with a jumper wire, the instrument will still display the current weight. NOTE: The control relay is a normally closed contactor in normal operation.

When overloaded, the relay will open and cut off the **UP** control circuit of the hoist. This device is part of the safety/protection system of a hoist. All testing, calibration and certifications must be performed by a qualified agency.

DO NOT USE HOIST UNTIL THIS UNIT IS PROPERLY CALIBRATED AND TESTED.

MOST FREQUENT MALFUNCTIONS AND SOLUTIONS:

1. Unable to display the loaded weight.

- a. Malfunction: After installation it displays "0". And after loaded still displays "0".
- b. Checking Methods: Long press both the ESC and SHIFT buttons for 3 seconds to view the current sampling voltage **.*
- c. Possible Solutions: If the sampling voltage displays *.* it shows a valid figure, it means the sensor and instrument are functioning properly. You will need to press the CLEAR button when no load is present. If the sampling voltage shows a negative value, it means the instrument failed to connect the sensor or reverse connection of the sensor signal wire or the sensor wire is broken. You will need to connect the sensor to the instrument properly or replace the faulty wiring or sensor.

2. Alarm after connection to the power supply (when no load is present)

- a. Malfunction: After connection to the power supply the unit displays **** or E-H and the red-light flashes and the alarm sounds.
- b. Checking Methods: Long press both the ESC and SHIFT button for 3 seconds to view the current sampling voltage *.*.
- c. Possible Solutions: After starting up if the sampling voltage is too high (greater than 2.00) it means the sensor is damaged or the wire is incorrectly connected. OR if the sampling voltage of the instrument is less than 2.00 and the figure also changes after loading it means the calibration is not correct and you will need to calibrate the instrument again.

NOTICES:

- 1 It is normal for the displayed figure to change due to weight swaying. The figure will be stable as the load weight becomes stationary. The slight difference of the weight between the upper and lower positions in hoisting is due to the change of the length of the steel rope on the drum as it winds, however, the weight deviation should be within $\pm 5\%$.
- 2 This device is intended for measuring weight as a safety device and is not intended for commerce.
- 3 Please strictly follow all recommended procedures listed in this manual to insure proper operation of this safety device.
- 4 This device should be inspected on a regular basis every 6 months. The particulars to be inspected include display accuracy and alarm set point etc.
- 5 The device has a 12-month limited warranty (from the date of shipment). Terms and conditions apply.

4.3.1.9 Trolley Frame

Check for proper shaft alignment with frame.

Check that all fasteners are at proper torque specifications.

Check for proper clearance of 3 to 5 mm on flange drive wheels.

Check that trolley drive motor brake is functioning properly.

4.3.2 Load test inspection (100% rated load)

4.3.2.1 Motor current

Check voltage and amperage on each leg of lifting motor power supply while under maximum load lifting operation at both speeds. Observe that each leg amperage is balanced with respect to the others and that none exceeds the FLA (full load amperage) rating on motor nameplate and that voltage is within required range per nameplate. If these measurements are in specification upon pre-use inspection be sure to document them and leave a copy in the control cabinet. These values will be useful when troubleshooting issues during the service life of the hoist.

4.3.2.2 Motor thermal protection

In operation of the hoist system if motor thermal protection is triggered frequently be sure to inspect electrical and mechanical aspects of the system as this could indicate a potential issue with the system. Also take note of the ambient temperature of the working environment of the hoist system as this could be a contributing factor as well. See section 2.1

4.3.2.3 Trolley System

Check operation of trolley motor at both low and high speeds and both directions of travel

Check that the drive wheels are not slipping, and that the motor brake securely locks trolley in place when stopped. Make sure the runway surface is not painted and free of debris.

It is good practice to run the full length of runway 3 to 5 times in both directions and observe for any issues.

4.3.3 Testing system in overload (110 to 125%)

4.3.3.1 Test overload device

Check that overload device prevents operation of hoist system.

4.3.3.2 Lifting motor brake

Lower test load in low speed and test that brake will hold load in place when motor is stopped.

4.3.4 System documentation

Please check that all documents included with the hoist system are in good order. Be sure to have all pre-use inspection documents properly filled out as well as owner required warranty cards and submitted to Starke. Keep inspection / maintenance logs in a safe place for reference in the service life of this hoist system.

5 Operation Manual

5.1 Control pendant

The typical control device of a hoist or crane system is the pendant. Pendants can be wired or wireless and perform the same functional control over the hoist / crane system.

Depending on the number of motions the system is capable of the number and function of buttons will vary by system. The most critical button is the **emergency stop (Estop)** button and is featured prominently by being red in color and a locking type of switch located at the top of the pendant for easy access. Once Estop is triggered all functions of the system will be disabled and must be manually reset before system is allowed to be put back in service. To reset Estop typically the button is rotated slightly to re-arm the trigger system within it and the button should raise up slightly.

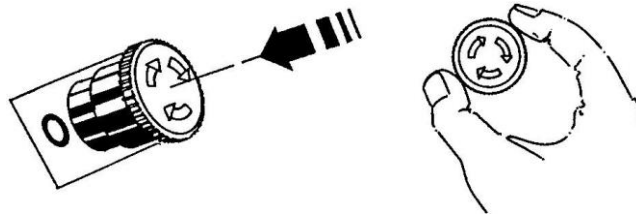

Note:

On most wireless radio pendants there will be a button called “start” and upon power up or resetting the Estop you will be required to press “start” to enable the system. This is an extra layer of safety to prevent unintentional operation of the system. In some cases, the radio system will automatically lock out the system after a period of inactivity that will also require pressing “start” to wake the system up.

The other buttons on the pendant are for motions the system can perform. The buttons typically are a two stage type. This means that by depressing the button halfway down the first speed of the motion is activated and by fully depressing the button the second speed of the motion is activated. The buttons are grouped by the motion they control, i.e. Up/Down, North/South, East/West. They are mechanically and/or electrically interlocked so that only one direction of motion for that grouping can be performed at a time.

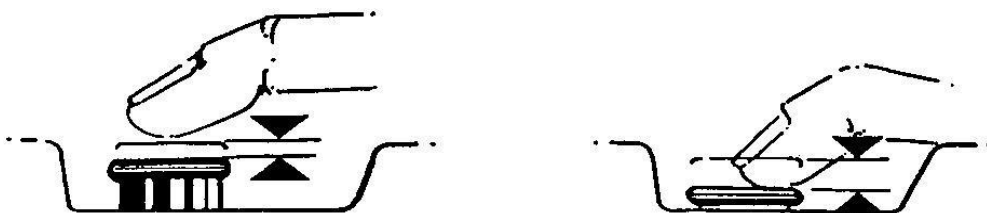

6 Inspection and repair

6.1 Inspection

Notice

It is recommended that a certified and accredited industrial hoist and crane service provider be utilized to inspect, maintain, and certify the hoist system. This organization should have the ability to provide the following.

- Provide technically qualified personnel familiar with hoist/crane systems and the maintenance of the electrical and mechanical components that comprise the system.
- Provide documentation of accreditation in service / inspection of hoist and crane systems that may be required by jurisdictions and underwriters.
- Understand and follow all on site, jurisdictional and underwriters' safety policies, and practices.
- Provide all documentation of inspection and maintenance records on the system to the owner and/or their representative.

6.1.1 Pre-use inspection of system

Ensure that wire rope hoists and load bearing structures are tested by experienced and certified personnel before placing this system in service.

The following items must be checked during the inspection and testing:

- That technical parameters of the wire rope hoist system are consistent with the nameplate and design of the system.
- If there are any potential safety risks not accounted for during the design, manufacture, and installation of the system.
- All safety devices such as limit switches, brakes and controls have been calibrated and function properly.

That there are no defects in the wire rope hoist system and load bearing structures that may affect the safety of personnel and property

- All structural inspection and testing results should be recorded in the maintenance log form.

- Based on the results of inspections and tests, the qualified commissioning personnel shall determine if system is certified to be placed in service or if further testing and/or corrective action is required
- If any defects are found during load testing, commissioning personnel shall have the right to re-test.

Notice

According to differing jurisdictional requirements, the content of the inspections and testing may differ. If the load testing requirement is to be performed at 110% the of rated load for the dynamic test and 125% of the rated load for static test, please contact your dealer for guidance on this subject.

6.1.2 Certification post overhaul and/or modification

Before placing hoist system back into service post overhaul/modification testing procedures outlined in section 6.1.1 should be performed on the system again

Overhaul and/or modifications may include but are not limited to.

- Relocation of hoist and/or structural support system
- Modifications such as welding or splicing runway/support columns
- Structural design changes of building attached supporting members.
- Modifications to control system wiring, functionality, programming

6.1.3 Routine inspections

To ensure the safe and reliable operation of this hoist system it is recommended that the hoist system be inspected annually by an accredited agency with personnel that are experienced in the operation and maintenance of industrial hoist/crane systems. Please contact your dealer for recommended service providers

Annual inspections should include but are not limited to:

- Record model and serial numbers of system components and pertinent nameplate data for reference. Also include user identification of system
- Inspect structural assembly for broken or worn components or the presence of corrosion, stress cracks, warping or bending.
- Validate all safety device functionality (Estop, lifting limiter, load limiter, horn/strobe, travel limits, motor brake function)

- Wear of motor bearings, support bearings, gearbox, and lubrication conditions
- Inspect electrical systems and terminals for loose wiring connections.
- Check VFD(s) cooling fan and heatsink for proper air flow, check brake resistor (if installed) is within tolerance of its nameplate specification.
- Unit “in service” hours and cycle count if available
- Wire rope condition (galling, abrasion, fraying, broken wires, corrosion), drum securing clamps are in good condition, lubrication conditions, rope guides function properly.
- Hook assembly reeving pulleys and hook rotation bearings

Note

If any of deficiencies are discovered during the inspection, the hoist system should remain out of service and locked out until remedial action is taken to correct the issue(s)

6.2 Inspection Checklist

Parts	Inspection content	Inspection cycle		
		Commissioning	Daily	regular
Brake	Functional Testing	X	X	X
	Brake gap			X
Overload limiter	Functional Testing	X		X
Wire rope	Visual damage situation		X	X
	Lubricating	X	X	X
	Wearing situation			X
Rope guide	Visual appearance and Accessories	X		X
Hooks	Visual damage situation		X	X
	If safe lock can rotate freely	X	X	X
	If safe lock can rotate freely	X	X	X
	Wearing of hook			X
Electronic control	Functional Testing	X	X	X
	If wire is loose			X
Limiting stopper of lifting	Functional Testing	X	X	X

Attention!

Only properly trained and certified technical personnel are authorized to maintain and service Starke wire rope hoist / crane systems.

Starke shall not be held liable and will not take any responsibility for any failure of or injury caused using non-authorized parts or service personnel, or incorrect maintenance, or the lack thereof. Please contact your dealer to obtain authorized parts and service for your Starke SMW hoist system.

6.3 Wire rope maintenance

6.3.1 Inspection of wire rope

Wire fractures will happen during normal use, because of continued wearing and fatigue stress. For safety reasons, it is required to check wire rope once a month. The hoist system shall be placed out of service and the wire rope must be changed if anyone of following three situations is discovered:

- Number of fractures is more than 4% of total amount of the distance and no longer than 6 times of wire rope's nominal diameter (FEM 1Bm~1Am)
- Number of fractures is more than 8% of total amount of the distance and no longer than 30 times of wire rope's nominal diameter (FEM 2m~4m) broken wire rope's strands.
- In addition, if wire rope has suffered severe mechanical injury, such as deformation of cage type, permanent deformation and so on, it must be changed immediately.

6.3.2 Maintenance and lubrication of wire rope

Maintenance personnel should perform necessary lubrication depending on the system usage. The ideal lubrication method is using cotton cloth wetted by worm gear lubrication oil to scrub the whole wire rope. If wire rope cannot be lubricated due to unforeseen circumstances, the service life of wire rope will be reduced and will require more frequent inspections.

6.3.3 Replacement of wire rope

- Place the empty hook on the holder and remove the cover of drum.
- Remove wire rope from the fixed end and then remove rope guide(s). Next loosen the bolts of clamping plates for wire rope retention, and then remove the whole wire rope.
- According to standards ISO-4309, place wire rope on the drum attachment points and torque clamping plates to the specified torque required (see chart for torque specifications).
- Carefully start the motor to wind appropriate amount of wire rope on drum, take the opposite end of wire rope and continue to route wire rope through hook block pulley(s) and reeving pulley(s)
- Once routing of the wire rope is correctly done affix the wedge block to the wire rope attachment point of the hoist
- Reinstall rope guide(s) and adjust as needed.
- Once the wire rope is installed set hook to lowest position and observe wire rope for any signs of twisting or warping. Loosen wedge block and relieve twisting stress on wire rope so that hook hangs correctly.

6.4 Cleaning and lubrication of rope guide

During normal use, the rope guide will receive lubrication through contact with the wire rope. It may also become necessary to separately lubricate the rope guide when maintaining the hoist. When lubricating, the rope guide should be removed from the drum assembly, and then apply grease to the friction surfaces. Reinstall the guide(s) carefully and adjust so that guide can freely move with winding of rope.

7. Troubleshooting

Attention! Lock out and tag out power supply before attempting any of these tests.

Fault Description	Possible Causes	Recommended Action	Remarks
Hoist doesn't operate	No power	Check power supply and collector Check emergency stop and contactor KI	
	Lifting limiter is tripped	Check limit switch	
Lifting motor doesn't operate	No power	Check phase sequence of main power Check voltage of main power	
	wiring error of main power supply line	correct wiring error	
	Fuse blown	Replace fuse	
	Malfunction of Push Button	Check buttons and wiring of pendant cable	
Lifting motor does not move, but has humming sound when pressing buttons	Wiring error	Check wiring of incoming main power and all 3 legs are present and phased correctly	Motor may be damaged
	Contactors error	Replace contactor	
	Brake doesn't open	Refer to the correction of brake adjustment errors	
	Push button may have failed	Check buttons and replace them if necessary	

Single-direction movement of lifting	Wiring faults	Check wiring	
	Lifting limiter is tripped	Check limiter	
	Faulty contactor	Check contactor	
Brake doesn't operate	Power supply failure for brake actuator	Check wiring of and/or replace brake pack	
	Failure of rectifier	Check wiring and power supply of brake coil Replace broken rectifier	
Braking not effective	Clearance of brake disc	Adjust clearance	
Excessive wear of wire rope	Insufficient lubrication of wire rope	Lubricate wire rope frequently	
	Solid attachments on wire rope	Clean wire rope frequently	
	Pulleys are worn/broken due to extreme use	Replace new parts	

8 Electrical Information

8.1 Electrical Specifications

Electrical Data - Motor and VFD									
Model #	Description	Unit Nominal Voltage: 460/3/60 Only					Brake Resistor Values	Suggested Fuse Rating (Amp)	Nominal Operating Amps
		Model Electrical Details (Trolley Danfoss VLT FC51 Equipped)							
		2 Spd Lifting Motor H.P. (Nominal)	2 Spd Lifting Motor kW (Nominal)	2 Sp Lifting Motor Amp (460v Nominal)	Trolley Motor VFD P/N	Trolley Motor Rated H.P. / (kW)			
SMW0324-20	3 Ton Wire Rope Hoist	0.7 / 5.1	0.5 / 3.8	2.7 / 7.2	132F0020	.85 / 0.7	60Ω 500w	10	1.0 ~ 1.4
SMW0524-20	5 Ton Wire Rope Hoist	1.4 / 9.6	1.1 / 7.2	2.4 / 15.6	132F0020	.85 / 0.7	60Ω 500w	10	1.0 ~ 1.4
SMW1021-20	10 Ton Wire Rope Hoist	2.4 / 15.2	4.2 / 9.2	9.0 / 20.0	132F0020	1.27 / 1.0	60Ω 500w	10	1.5 ~ 2.1

8.2 Electrical schematics

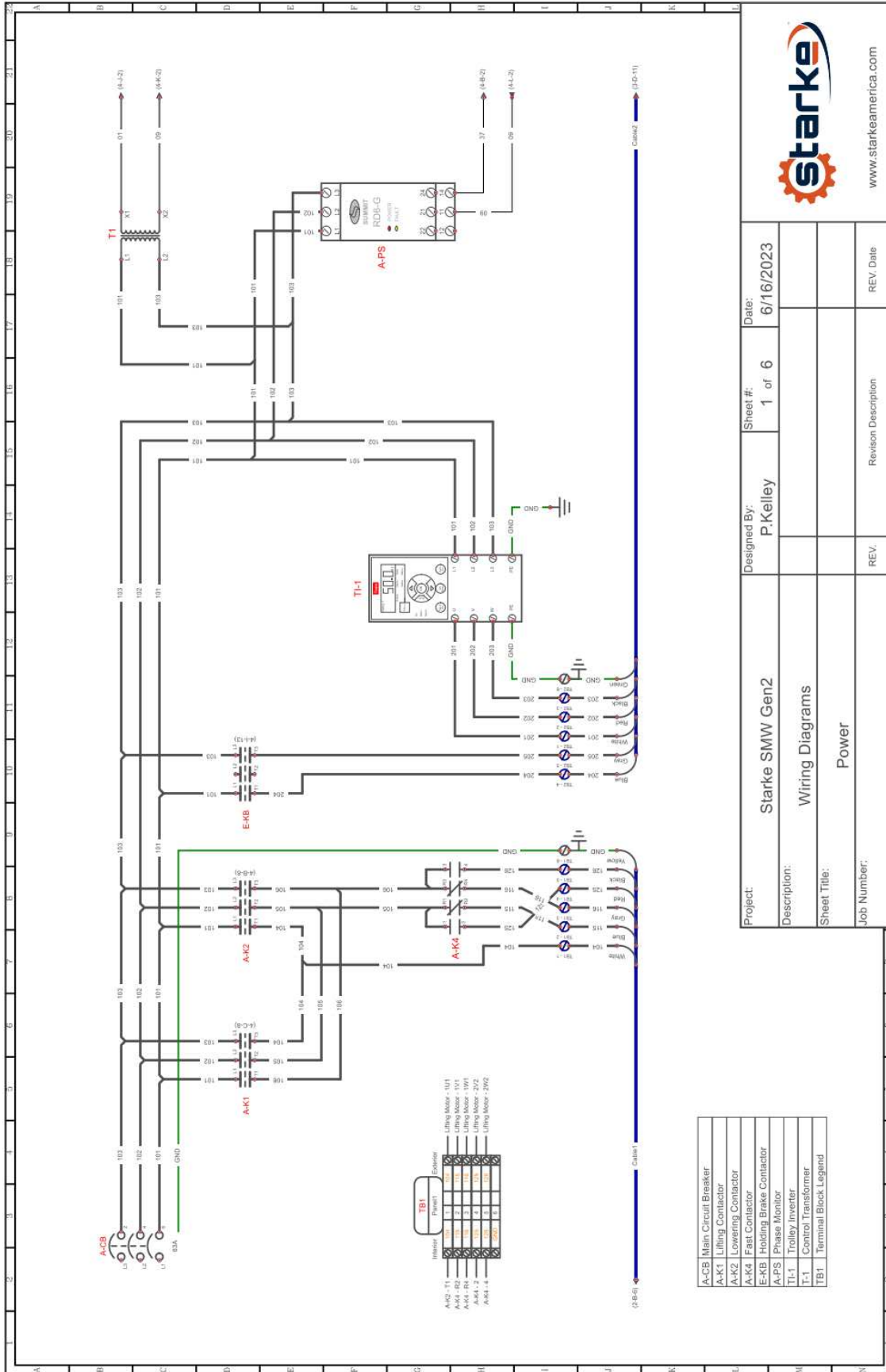

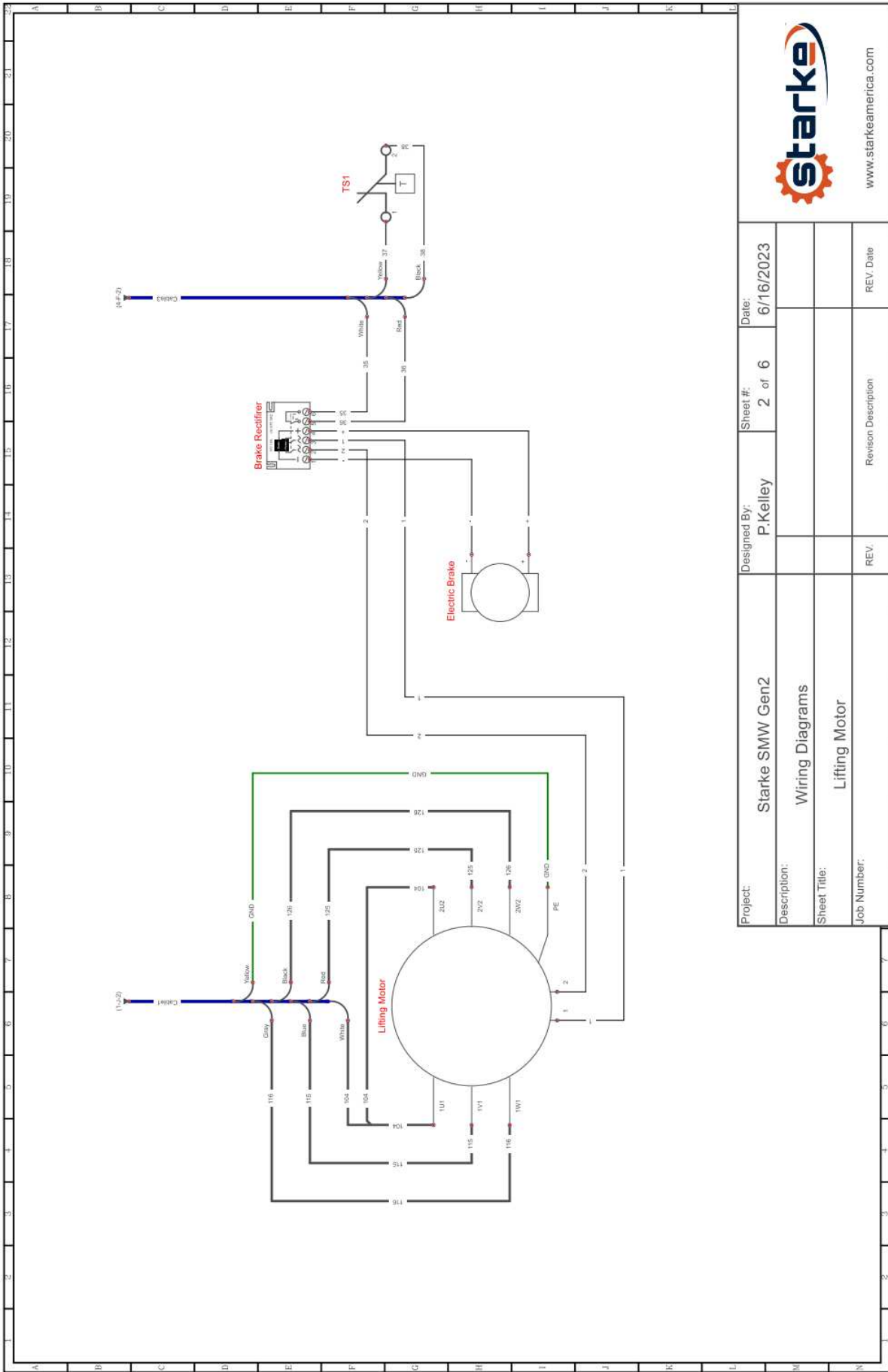

Project:	Starke SMW Gen2	Designed By:	P. Kelley	Sheet #:	2 of 6	Date:	6/16/2023
Description:	Wiring Diagrams						
Sheet Title:	Lifting Motor						
Job Number:		REV.		Revision Description		REV. Date	



www.starkeamerica.com

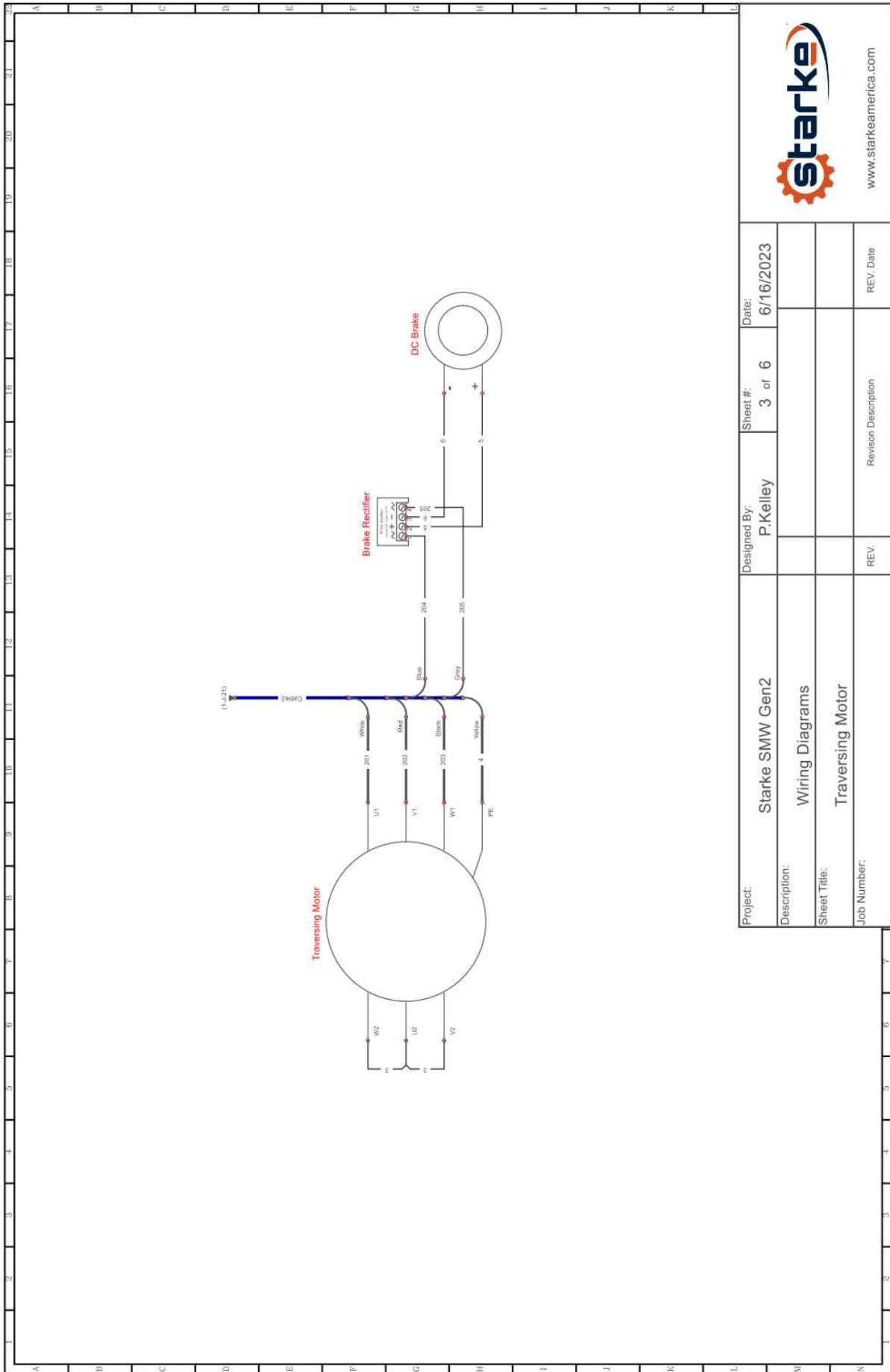

Project:	Starke SMW Gen2	Designed By:	P.Kelley	Sheet #:	3 of 6	Date:	6/16/2023
Description:	Wiring Diagrams						
Sheet Title:	Traversing Motor						
Job Number:		REV	Revision Description			REV Date	



www.starkeamerica.com

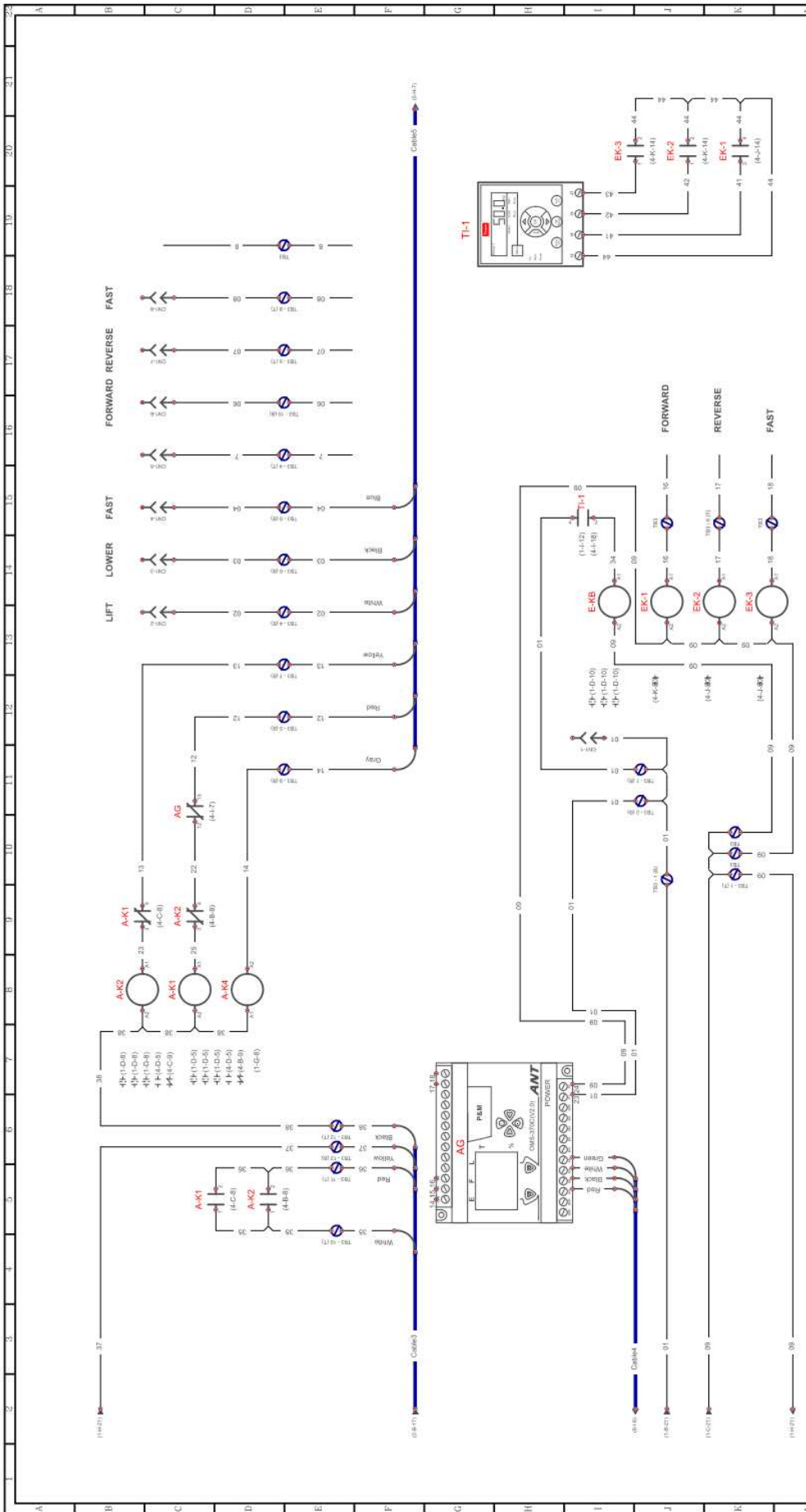

Project:	Starke SMW Gen2	Designed By:	P.Kelley	Sheet #:	4 of 6	Date:	6/16/2023
Description:	Wiring Diagrams						
Sheet Title:	Controls						
Job Number:		REV.	Revision Description			REV. Date	



www.starkeamerica.com

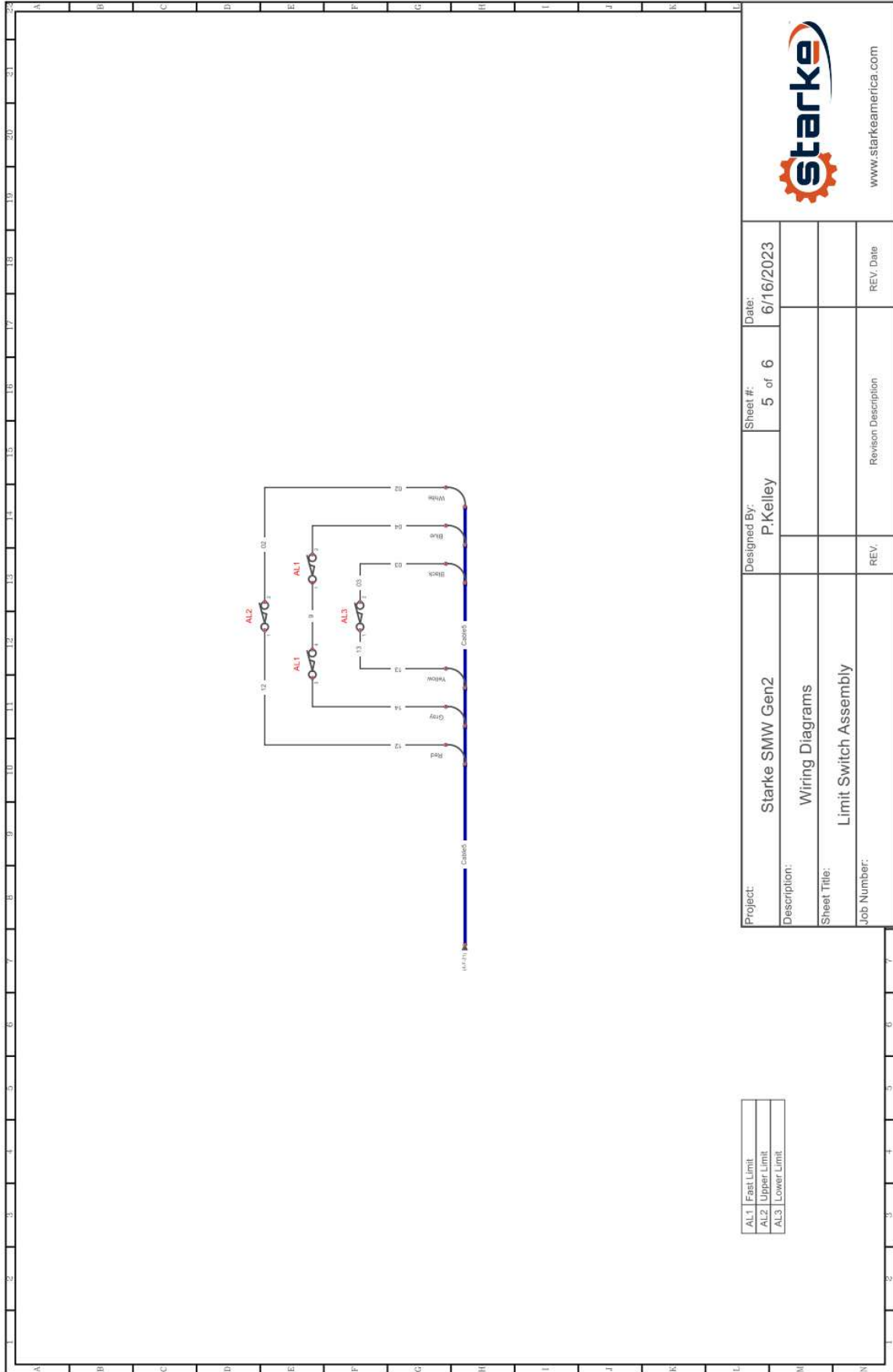

AL1	Fast Limit
AL2	Upper Limit
AL3	Lower Limit

Project:	Starke SMW Gen2	Designed By:	P.Kelley	Sheet #:	5 of 6	Date:	6/16/2023
Description:	Wiring Diagrams						
Sheet Title:	Limit Switch Assembly						
Job Number:		REV.		Revision Description		REV.	REV. Date



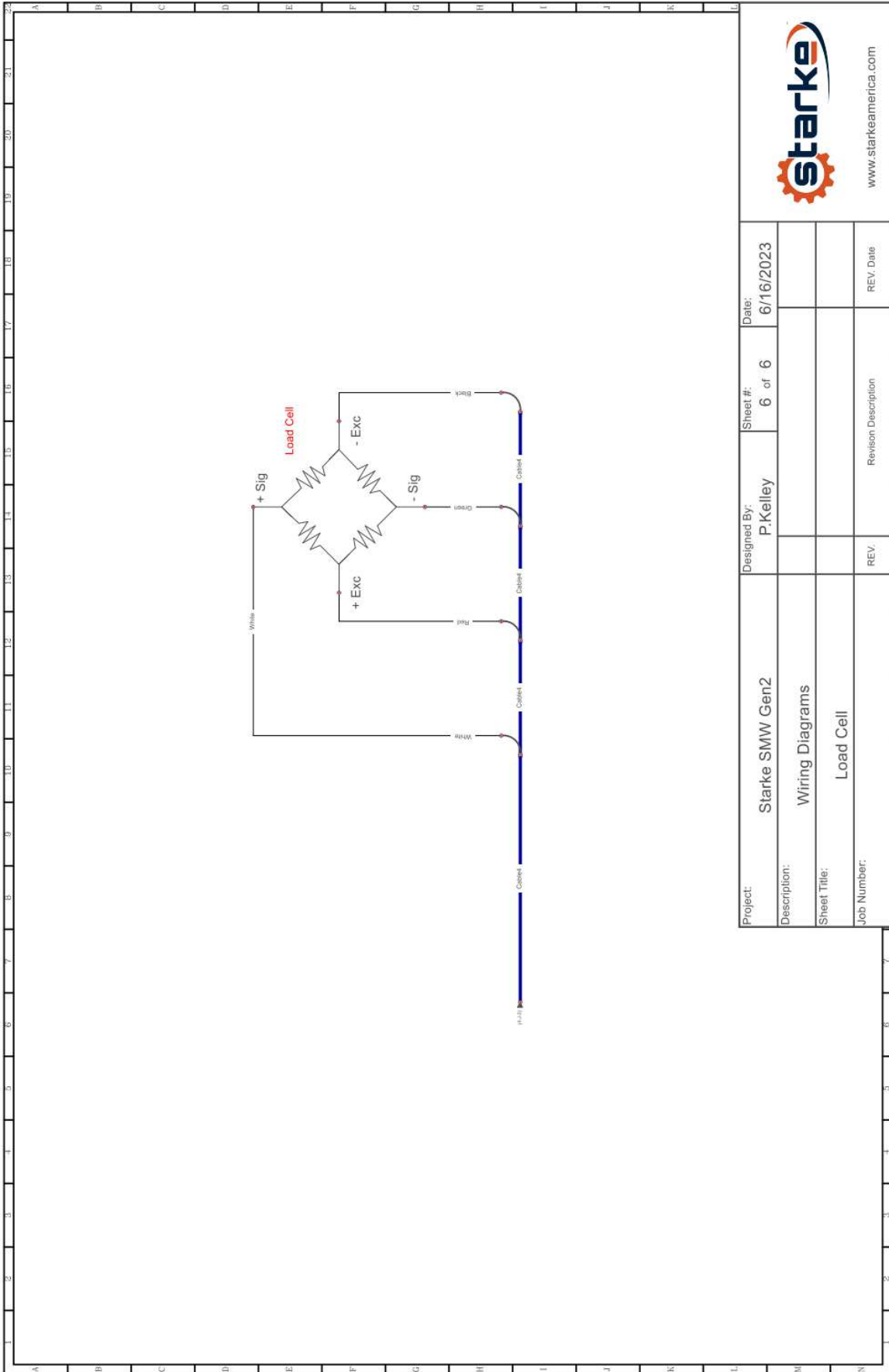

Project:	Starke SMW Gen2	Designed By:	P.Kelley	Sheet #:	6 of 6	Date:	6/16/2023
Description:	Wiring Diagrams						
Sheet Title:	Load Cell						
Job Number:		REV:		Revision Description		REV. Date	



Device Name	Code Name	Phase Sequence	A-PS
Contactors	A-K1	Height Limiator	AL
Contactors	A-K2	Trolley Limiator	EL
Contactors	A-K4	Contactors	A-F1
Contactors	A-K3	Connectors	CZ11
Contactors	E-KB	Connectors	CZ12
Intermediate Relay	E-K1	Overload Limiator	AG
Intermediate Relay	E-K2		
Intermediate Relay	E-K3		
Brake Resistor	BR		
Inverter	INVERTER		

9 Product information

9.1 Wire rope hoist maintenance-form

Below table to be filled in by client:

To be completed by the customer	
Company:	_____

Date commissioned:	_____
Location	_____

Manufacturer:

Address:

Service hot line:

Type:

Serial number:

Manufacture date:

Working group:

Rated load:

Lifting height:

Lifting speed:

Electrical outlet:

9.2 Wire rope hoist yearly inspection record

Attached yearly inspection record.

No	Inspection items	Test result	Inspector	Date
1				
2				
3				
4				
5				
6				
7				
8				
9				
10				
11				
12				
13				
14				
15				
16				
17				

10. Exploded part drawings.

A. Single girder wire rope general drawing

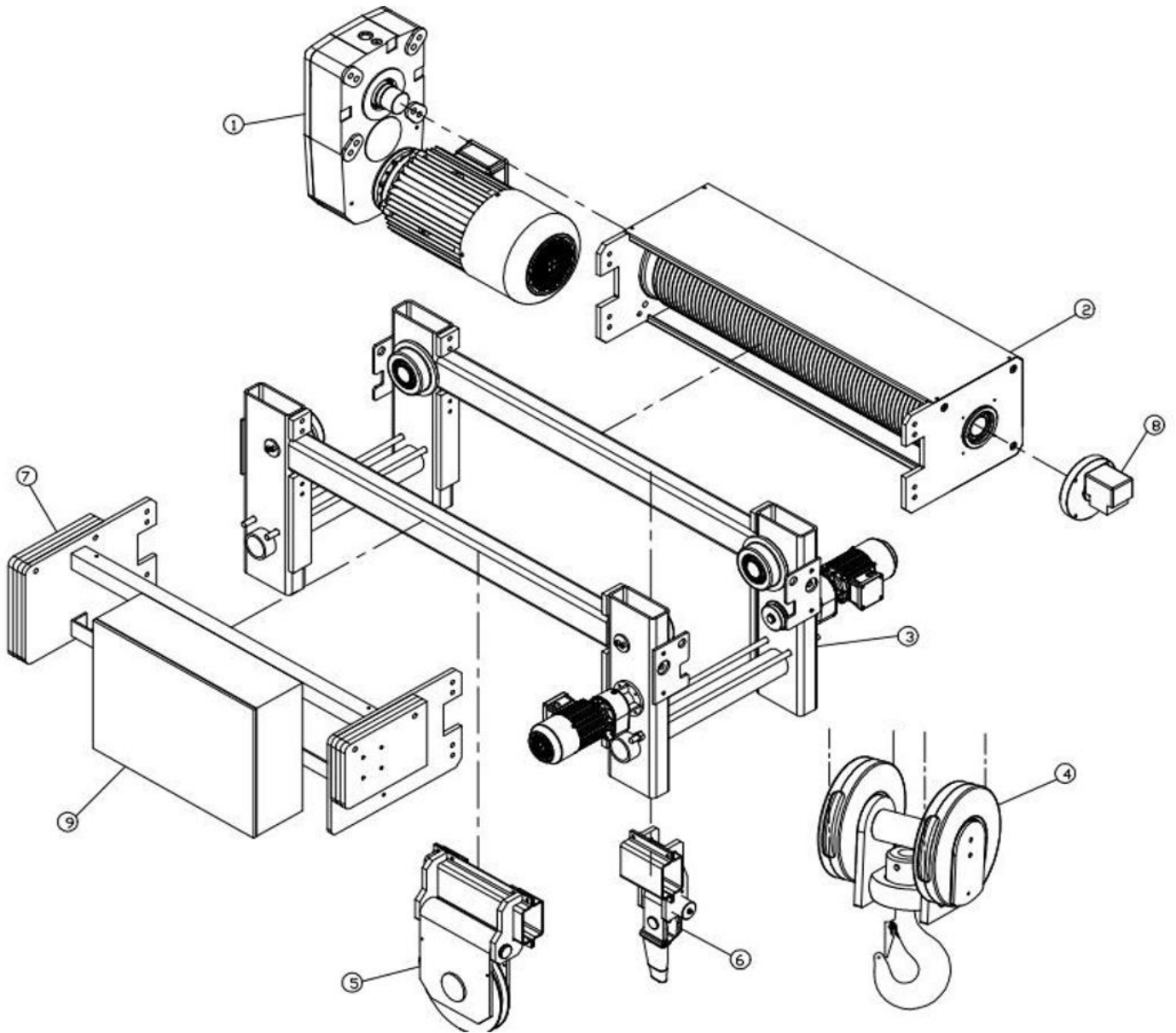

Section #	Description
A1	Lifting Motor & Gearbox
A2	Lifting Device
A3	Traveling Device
A4	Lower Hook & Block
A5	Fixed Pulley Assembly
A6	Wedge Assembly

A1 Lifting motor drawing.

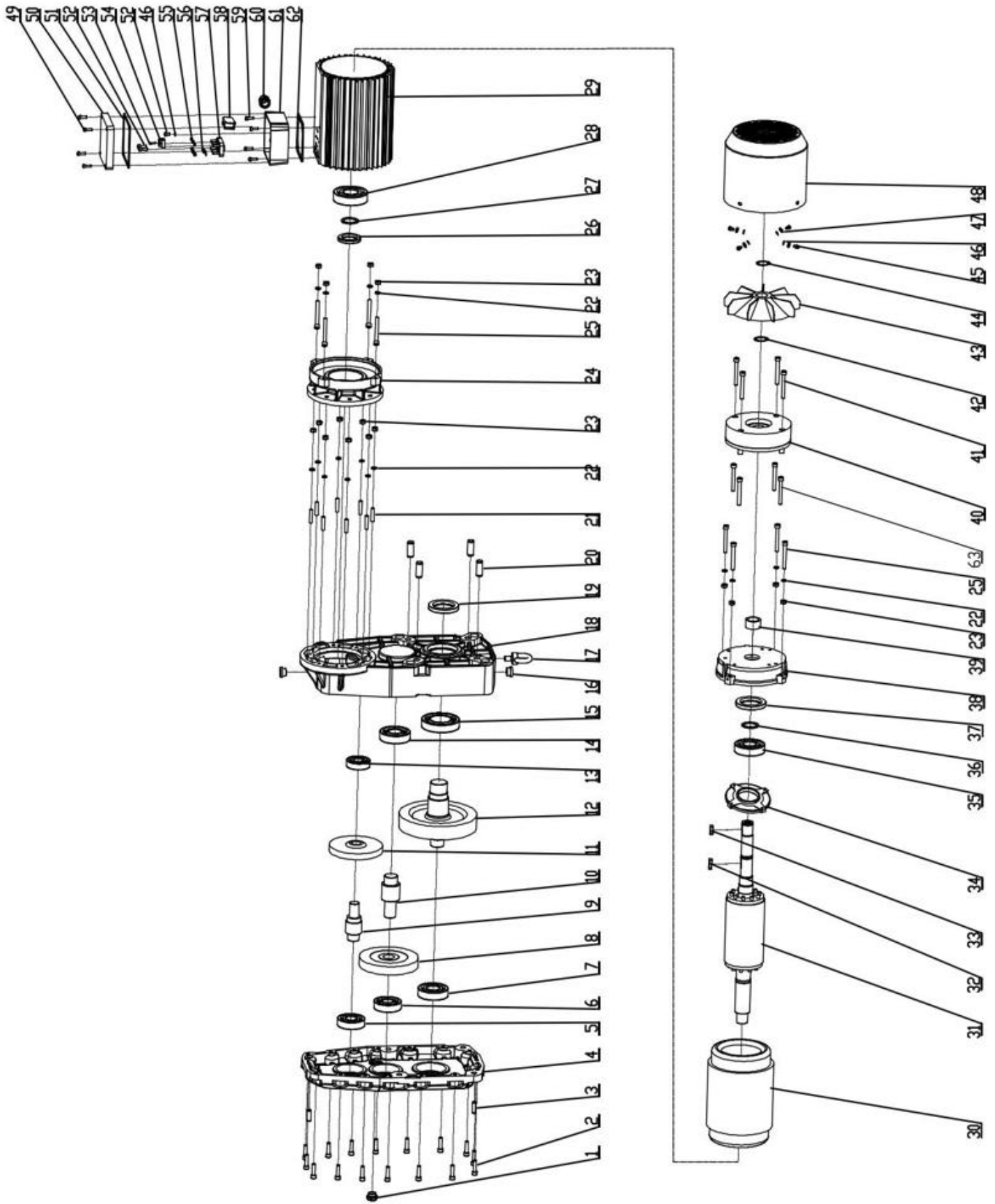

Lifting Motor & Gearbox

Ref #	Description	3 Ton	5 Ton	10 Ton
1	Gearbox Assy Includes Ref #1-20	600-43000	600-43001	600-43002
2	Hexagon socket head cap screws	NSS	NSS	NSS
3	Dowel pin	NSS	NSS	NSS
4	Box cover plate	NSS	NSS	NSS
5	Bearing	NSS	NSS	NSS
6	Cylindrical roller bearing 310E	NSS	NSS	NSS
7	Bearing	NSS	NSS	NSS
8	Intermediate disc gear	NSS	NSS	NSS
9	Intermediate shaft gear	NSS	NSS	NSS
10	Output disc gear	NSS	NSS	NSS
11	Input disc gear	NSS	NSS	NSS
12	Output gear	NSS	NSS	NSS
13	Bearing	NSS	NSS	NSS
14	Cylindrical roller bearing	NSS	NSS	NSS
15	Cylindrical roller bearing	NSS	NSS	NSS
16	Oil plug	NSS	NSS	NSS
17	Rings	NSS	NSS	NSS
18	Box	NSS	NSS	NSS
19	Oil seal	600-43006	600-43007	600-43008
20	Dowel pin	NSS	NSS	NSS
21	Motor Assy Includes Ref #'s 21-63	600-43003	600-43004	600-43005
22	Spring washer	NSS	NSS	NSS
23	Nuts	NSS	NSS	NSS
24	Motor front cover	NSS	NSS	NSS
25	Hexagon socket head cap screws	NSS	NSS	NSS
26	Skeleton oil seal	NSS	NSS	NSS
27	Wave mat	NSS	NSS	NSS
28	Bearing	NSS	NSS	NSS
29	Motor shell	NSS	NSS	NSS
30	Stator	NSS	NSS	NSS
31	Rotor	NSS	NSS	NSS
32	Ordinary flat key B	NSS	NSS	NSS
33	Ordinary flat key A	NSS	NSS	NSS
34	Small end cap	NSS	NSS	NSS
35	Bearing	NSS	NSS	NSS

Lifting Motor & Gearbox

Ref #	Description	3 Ton	5 Ton	10 Ton
36	Bearing Washer	NSS	NSS	NSS
37	Skeleton oil seal	NSS	NSS	NSS
38	Motor cover	NSS	NSS	NSS
39	Shaft sleeve	NSS	NSS	NSS
40	Brake Includes 40 & 41	600-43009	600-43010	600-43011
40A	Brake disc (not shown)	600-43054	600-43055	600-43056
41	Hexagon socket head cap screws	NSS	NSS	NSS
42	Circlip for shaft	NSS	NSS	NSS
43	Cooling fan	600-43012	600-43013	600-43014
44	Circlip for shaft	NSS	NSS	NSS
45	Hexagon socket head cap screws	NSS	NSS	NSS
46	Flat washer	NSS	NSS	NSS
47	Spring washer	NSS	NSS	NSS
48	Cooling fan cover	600-43015	600-43016	600-43017
49	Hexagon socket head cap screws	NSS	NSS	NSS
50	Terminal box cover	NSS	NSS	NSS
51	Terminal box cover Rubber mat	NSS	NSS	NSS
52	Hexagon socket head cap screws	NSS	NSS	NSS
53	Hexagon socket head cap screws	NSS	NSS	NSS
54	Terminal protector	NSS	NSS	NSS
55	Nuts	NSS	NSS	NSS
56	Connect plate	NSS	NSS	NSS
57	Terminal	NSS	NSS	NSS
58	Rectifier	600-43057	600-43058	600-43059
59	Hexagon socket head cap screws	NSS	NSS	NSS
60	Gland	NSS	NSS	NSS
61	Terminal box	NSS	NSS	NSS
62	Terminal box cover Rubber mat	NSS	NSS	NSS
63	Hexagon socket head cap screws	NSS	NSS	NSS

A2 Lifting device drawing.

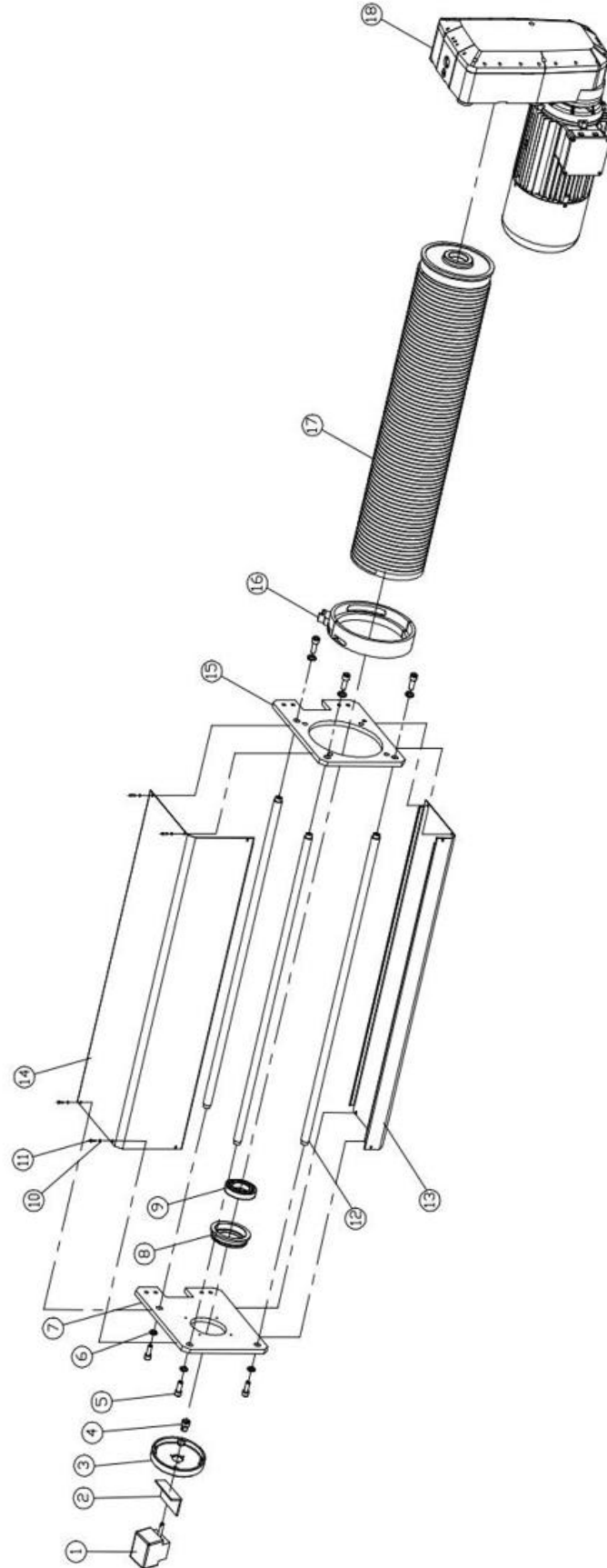

Lifting Device

Ref #	Description	3 Ton	5 Ton	10 Ton
1	Limit Switch	600-43018	600-43019	600-43020
2	Connect plate	NSS	NSS	NSS
3	Connector	NSS	NSS	NSS
4	Connecting sleeve	NSS	NSS	NSS
5	Hexagon socket head cap screws	NSS	NSS	NSS
6	Flat washer	NSS	NSS	NSS
7	Left flange	NSS	NSS	NSS
8	Bearing block	NSS	NSS	NSS
9	Bearing	NSS	NSS	NSS
10	Flat washer	NSS	NSS	NSS
11	Hexagon socket head cap screws	NSS	NSS	NSS
12	Connecting rod	NSS	NSS	NSS
13	Lower cover plate	NSS	NSS	NSS
14	Top cover plate	NSS	NSS	NSS
15	Right flange	NSS	NSS	NSS
16	Rope Guide	600-43021	600-43022	600-43023
17	Wire Rope Drum	600-43024	600-43025	600-43026
18	Lifting Motor	See Section A1 for Breakdown		

A3 Trolley device drawing.

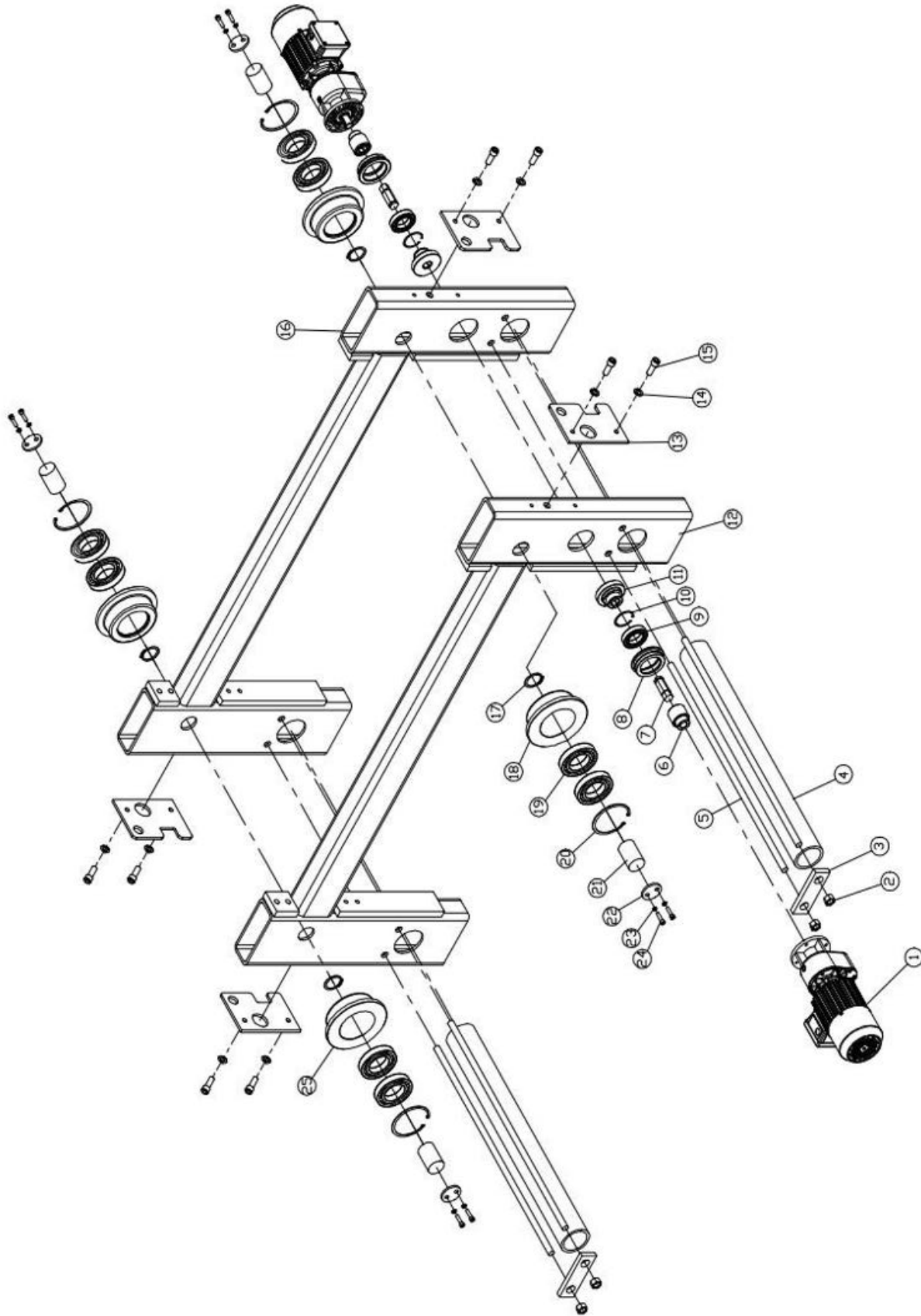

Traveling Device

Ref #	Description	3 Ton	5 Ton	10 Ton
1	Motor	600-43033	600-43034	600-43035
2	I-type hex nut	NSS	NSS	NSS
3	Positioning plate	NSS	NSS	NSS
4	Supporting tube	NSS	NSS	NSS
5	Positioning tube	NSS	NSS	NSS
6	Coupling	NSS	NSS	NSS
7	Transmission shaft	NSS	NSS	NSS
8	Bearing block	NSS	NSS	NSS
9	Bearing	NSS	NSS	NSS
10	Retaining ring for hole	NSS	NSS	NSS
11	Gear	NSS	NSS	NSS
12	Trolley frame A	NSS	NSS	NSS
13	Safe hook	NSS	NSS	NSS
14	Flat washer	NSS	NSS	NSS
15	Hexagon socket head cap screws	NSS	NSS	NSS
16	Trolley frame B	NSS	NSS	NSS
17	Retaining ring for shaft	NSS	NSS	NSS
18	Drive wheel	600-43027	600-43028	600-43029
19	Bearing	NSS	NSS	NSS
20	Retaining ring for hole	NSS	NSS	NSS
21	Trolley wheel shaft	NSS	NSS	NSS
22	Shaft cover	NSS	NSS	NSS
23	Spring washer	NSS	NSS	NSS
24	Hexagon socket head cap screws	NSS	NSS	NSS
25	Trolley wheel	600-43030	600-43031	600-43032

A4 Bottom hook drawing.

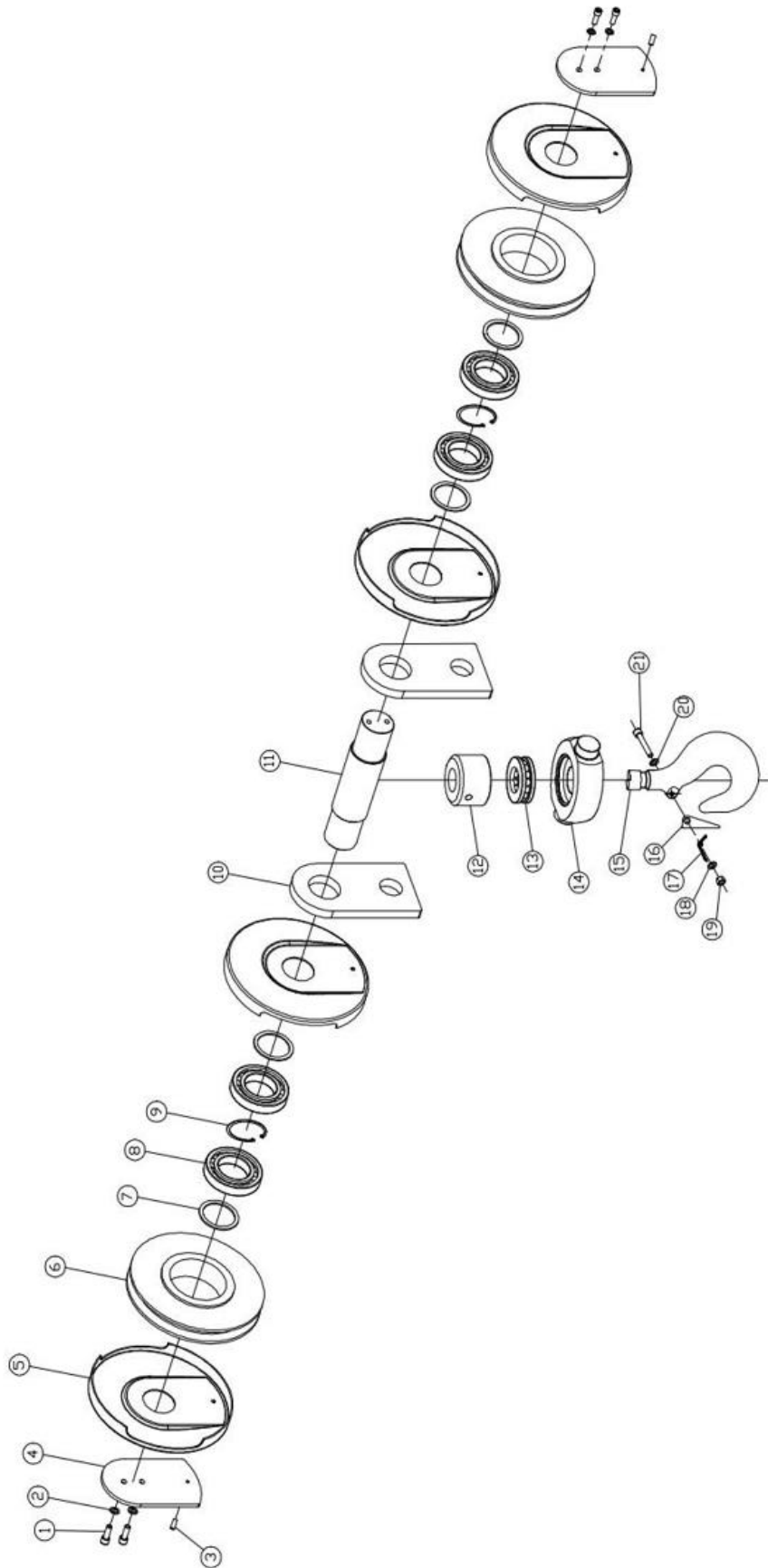

Lower Hook & Block

Ref #	Description	3 Ton	5 Ton	10 Ton
1	Lower Block Assy - Includes # 1-21	600-43036	600-43037	600-43038
2	Spring washer	NSS	NSS	NSS
3	Elastic cylindrical pin	NSS	NSS	NSS
4	Outboard	NSS	NSS	NSS
5	Side Cover	600-43039	600-43040	600-43041
6	Pulley	NSS	NSS	NSS
7	Washer	NSS	NSS	NSS
8	Bearing	NSS	NSS	NSS
9	Retaining ring for hole	NSS	NSS	NSS
10	Inner lift plate	NSS	NSS	NSS
11	Pulley shaft	NSS	NSS	NSS
12	Hook screw	NSS	NSS	NSS
13	Bearing	NSS	NSS	NSS
14	Load-bearing beam	NSS	NSS	NSS
15	Lower hook	NSS	NSS	NSS
16	Safety Latch	600-43042	600-43043	600-43044
17	Safety Latch spring	NSS	NSS	NSS
18	Flat washer	NSS	NSS	NSS
19	Self-locking nuts	NSS	NSS	NSS
20	Flat washer	NSS	NSS	NSS
21	Hexagon socket head cap screws	NSS	NSS	NSS

A5 Fixed pulley device.

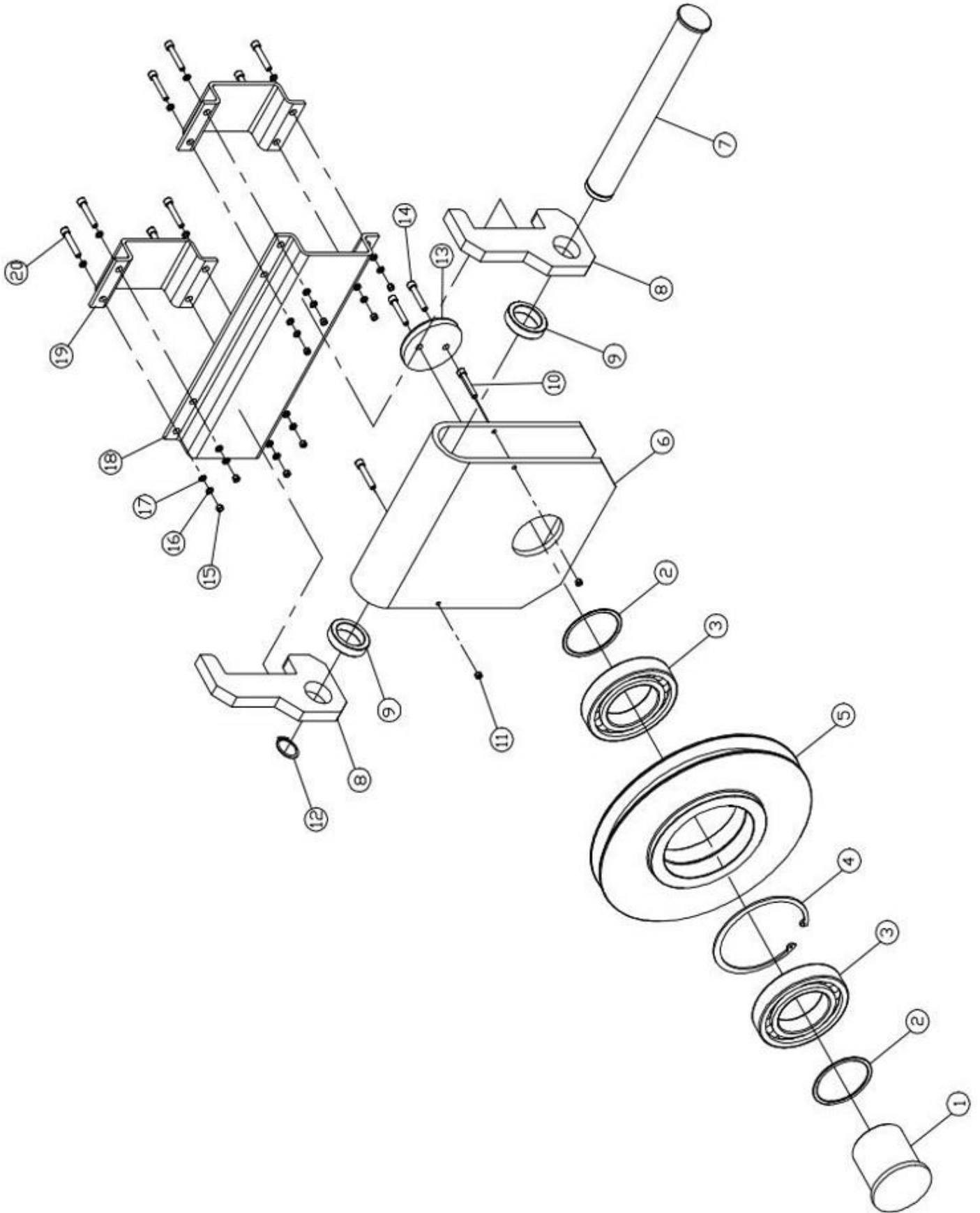

Fixed Pulley Assembly

Ref #	Description	3 Ton	5 Ton	10 ton
1	Pulley Assy Includes #'s 1-7 & 10-14	600-43045	600-43046	600-43047
2	Washer	NSS	NSS	NSS
3	Bearing	NSS	NSS	NSS
4	Retaining ring	NSS	NSS	NSS
5	Pulley	NSS	NSS	NSS
6	Lift Plate	NSS	NSS	NSS
7	Support Shaft	NSS	NSS	NSS
8	Hanging board	NSS	NSS	NSS
9	Bushing	NSS	NSS	NSS
10	Hexagon socket head cap screws	NSS	NSS	NSS
11	Self-locking nuts	NSS	NSS	NSS
12	Shaft retaining ring	NSS	NSS	NSS
13	Retaining ring cover	NSS	NSS	NSS
14	Hexagon socket head cap screws	NSS	NSS	NSS
15	Self-locking nuts	NSS	NSS	NSS
16	Spring washer	NSS	NSS	NSS
17	Flat washer	NSS	NSS	NSS
18	Connector plate	NSS	NSS	NSS
19	Connector plate	NSS	NSS	NSS
20	Hexagon socket head cap screws	NSS	NSS	NSS

A6 Rope end fixing device.

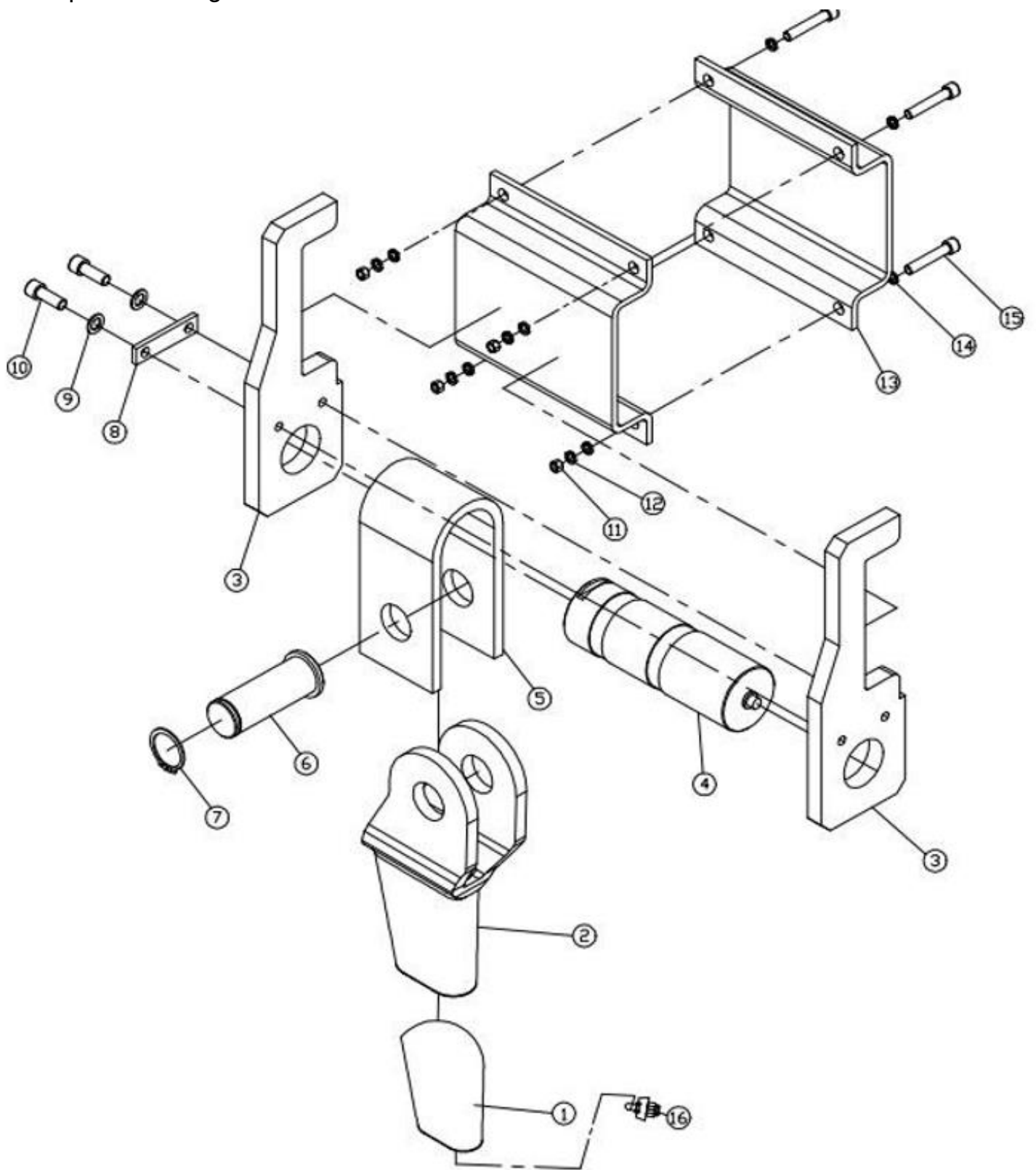

Wedge Assembly

Ref #	Description	3 Ton	5 Ton	10 Ton
1	Wedge Assy Includes Ref #'s 1-2	600-43048	600-43049	600-43050
2	Wedge joint	NSS	NSS	NSS
3	Ganging board	NSS	NSS	NSS
4	Overload protector	600-43050	600-43051	600-43052
5	Hanging board	NSS	NSS	NSS
6	Shaft pin	NSS	NSS	NSS
7	External Circlips	NSS	NSS	NSS
8	Fixed shaft plate	NSS	NSS	NSS
9	Spring washer	NSS	NSS	NSS
10	Hexagon socket head cap screws	NSS	NSS	NSS
11	Self-locking nuts	NSS	NSS	NSS
12	Spring washer	NSS	NSS	NSS
13	Connect plate	NSS	NSS	NSS
14	Flat washer	NSS	NSS	NSS
15	Hexagon socket head cap screws	NSS	NSS	NSS
16	Wire rope grips	NSS	NSS	NSS



Starke Products Warranty

1 Year (12 Month) Parts & Labor Warranty

Unless otherwise specified, Starke guarantees that our products are free from material defects in design and workmanship under normal use, proper maintenance, and service.

This warranty is strictly limited to 12 months for single shift operation or 2,000 hours after installation, or 14 months after shipment, whichever is shorter. Within ten days after defect is found, warrantee must deliver a written notice to Starke providing defect information. All requested warranty information must be received promptly by Starke in no more than 5 business days.

Customer is responsible for all shipping charges on returned/warrantable items. Starke will cover the repair (parts and labor) at no charge or provide a replacement item at Starke's discretion.

This warranty does not cover defects or damage caused by acts of God, unusual wear and tear, improper use, or improper maintenance by the user. No responsibility for consequential damage is expressed or implied, and the responsibility under this warranty/guaranty is limited to the repair or replacement of defective materials. Repair or replacement of the item is fully at the discretion of Starke.

ALL OTHER REPRESENTATIONS, EXPRESS OR IMPLIED, WARRANTY, OR LIABILITY RELATING TO THE CONDITION OR USE OF THE PRODUCT ARE SPECIFICALLY DISAVOWED, AND IN NO EVENT SHALL STARKE BE LIABLE TO BUYER, OR ANY THIRD PARTY, FOR ANY DIRECT OR INDIRECT CONSEQUENTIAL OR INCIDENTAL DAMAGES

STARKE
Starkeamerica.com/contact-us/