

ULTRALITE Tie Rod Jib Crane Systems



Installation, Operation, & Maintenance Manual

ULTRALITE
SERIES



Safety	2
Pre-Installation Checklist & Capacity info	3
Pre-assembly & Installation	5
Installation of Electrification	9
Crane Operator Basic Instructions	10
Warranty	13
Periodic Inspections	15

Date purchased _____

SN _____

Order Number _____

Product specifications and dimensions are approximate and for informational purposes only. Variations may occur due to design or manufacturing adjustments. For exact measurements, please confirm with our customer service before ordering. PWI reserves the right to modify specifications without notice.



ULTRALITE Tie Rod Jib Crane Systems



Before you begin. Read the instructions carefully, from beginning to end, and follow the proper sequence.

Thank you for purchasing a PWI crane! We have been building overhead cranes for years and our experience and knowledge should give you peace of mind. We too use overhead cranes in our manufacturing processes. From design & engineering, all the way to installation of our crane systems, our experience and passion for quality crane systems is shown in our products. We hope you find the installation ease and use of our PWI products to be among the best items you have purchased.

Thank you from the entire staff at PWI.

General Safety:

- Safety comes first when unloading and assembling your crane system. Many of the components are heavy and require lifting equipment to move and set them in place. Make sure the equipment you choose to support and lift each piece is capable of the task with extra capacity to do the job. Do not end up in a dangerous situation.
- Start with checking any lifting fixtures/tools for damage or wear that could lead to severe injury or death.
- This manual assumes that you have performed any foundation analysis ahead of placing your crane system in the proper location. Failure to provide the proper footing depth and width based on your column loads can result in failure of the floor structure supporting your crane.
- Please call PWI if you are unsure of the slab/foundation requirements for your crane system.

WARNING

There must be 3" minimum clearance to any obstruction above the unit.



Product specifications and dimensions are approximate and for informational purposes only. Variations may occur due to design or manufacturing adjustments. For exact measurements, please confirm with our customer service before ordering. PWI reserves the right to modify specifications without notice.



ULTRALITE Tie Rod Jib Crane Systems



Pre-Installation Checklist:

- Check your shipment for the correct components and hardware. Your shipment should include shipping sheets that were checked off by our team
- Check your shipment for drawings for layout and installation of components
- Clear the area as much as possible of items that could be damaged or create hazards during the installation. When assembling near electrical panels be aware of any regulations regarding perimeters required around those objects
- Forklift or suitable lifting equipment
- Should you have any technical questions, or feel you have defective components or missing items, call us immediately. We will be glad to assist you.

Possible Tools Needed:

- Proper PPE
- Forklift/Lifting Equipment
- Ladder/Man Lift
- Nylon Lifting Sling
- Marker
- Tape Measure
- Chalk Line
- Level
- Hammer
- Torque Wrench
- Wrench Set
- Laser Level
- Paint Brush
- Hammer Drill
- Hammer Drill Bits

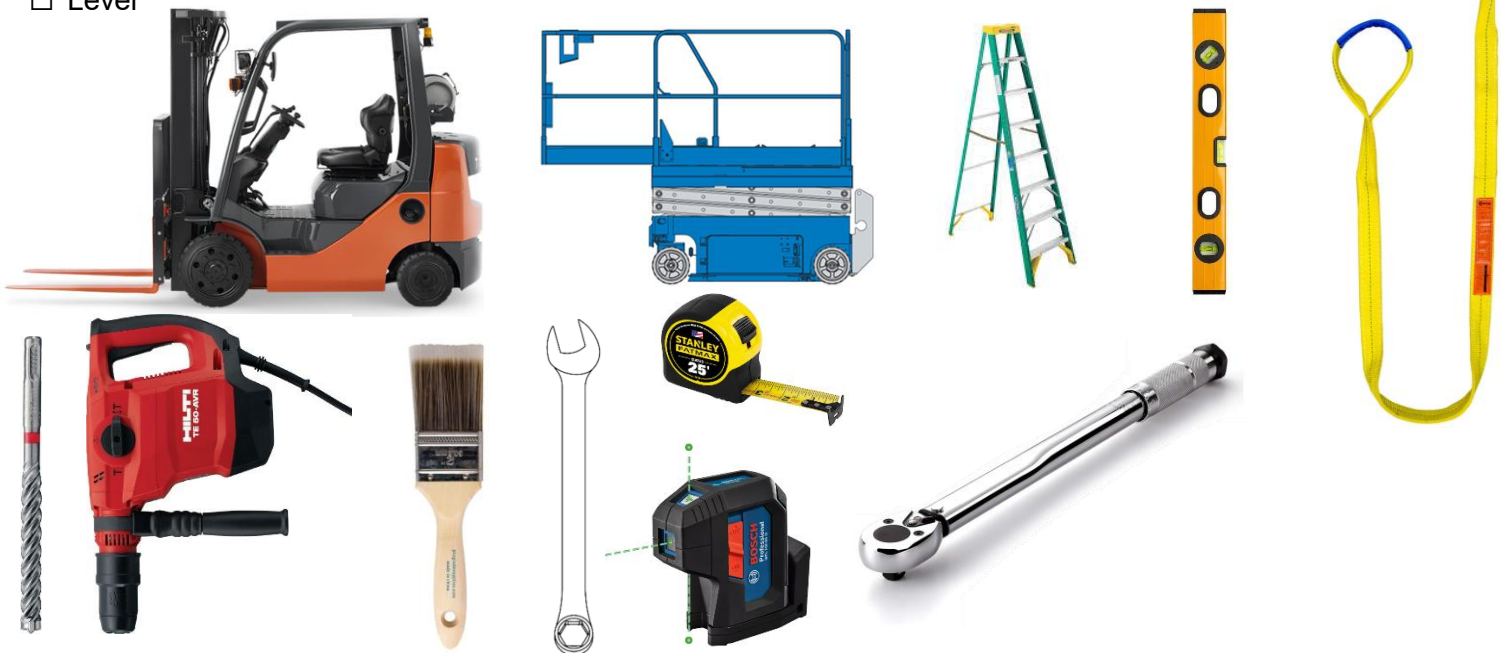

Product specifications and dimensions are approximate and for informational purposes only. Variations may occur due to design or manufacturing adjustments. For exact measurements, please confirm with our customer service before ordering. PWI reserves the right to modify specifications without notice.



ULTRALITE Tie Rod Jib Crane Systems



System Capacity Information:

The innovative design and heavy-duty construction of the PWI Tie Rod Jib Crane system will provide a superior quality product that will offer years of long-term value. The hoist weight allowance is 15% of the cranes capacity (for example, a crane rated for 6000 pounds allows for a 6000-pound live load plus 900 pounds for the weight of the hoist). There is also an allowance of 15% of the crane capacity for impact caused by hoist use. PWI Tie Rod Jib Crane systems will provide many years of dependable service by following the installation and maintenance procedures described herein.

Note: Any dimensions shown in this manual are for illustration purposes only. Refer to the drawings that were sent with your system for the exact measurements and configuration of the system we built for you.

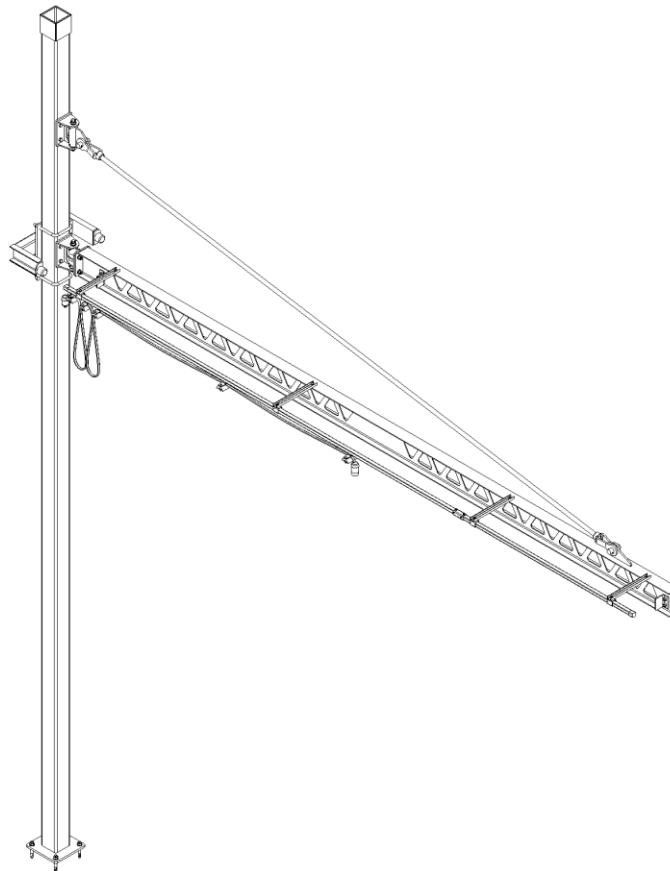

Product specifications and dimensions are approximate and for informational purposes only. Variations may occur due to design or manufacturing adjustments. For exact measurements, please confirm with our customer service before ordering. PWI reserves the right to modify specifications without notice.



ULTRALITE Tie Rod Jib Crane Systems



Step 1. Jib Crane Installation

1. Lay out the parts of the PWI Tie Rod Jib Crane

- | | |
|-----------------------------|--------------------------------------|
| (2) Thread clevis | (2) Clevis Pins |
| (1) Tie Rod | (2) Cotter Pins |
| (1) Hinge Kit with hardware | (1) Upper Mount, tie rod |
| (1) Jam nut | (1) Jib rotation stop kit (optional) |
| (1) I-beam | |

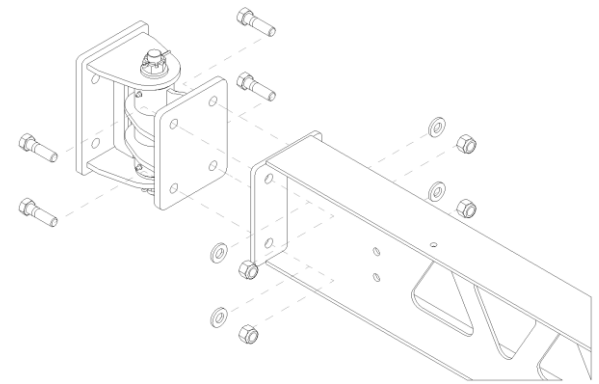

Image 1.2 Lower Hinge to Jib

2. Assembly of the jib crane will require temporarily bolting the lower hinge to the jib horizontal beam. Loosely bolt the lower hinge with the provided hardware as shown to verify the bolt pattern is correct. **(Image 1.2)**

3. Remove the hinge, press the hinge up to your mounting structure at your desired height, and mark out the holes of the hinge on the structure. **(Image 1.3)**

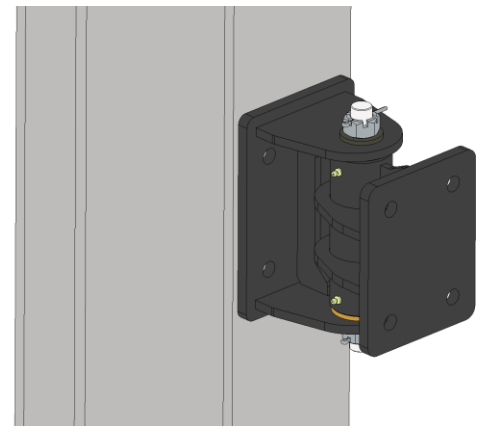

Image 1.3 Lower Hinge on Mount

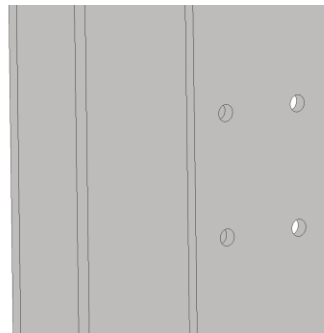

Image 1.4 Drilled Holes

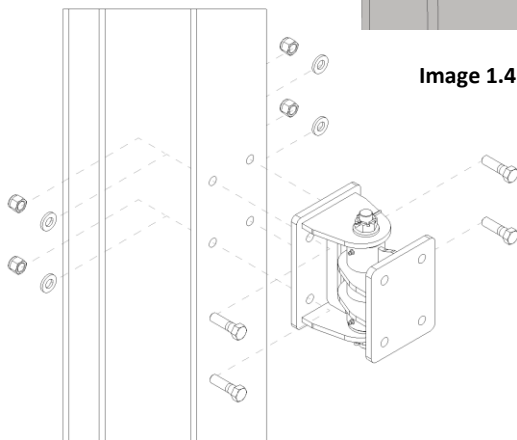

Image 1.5 Bolted Hinge Exploded View

4. Use a level to verify the hole markings are level, and drill holes as needed in your column/structure using the hinge bolt pattern as your guide. Check drawings for hole size. **(Image 1.4)**
5. Bolt the hinge to the column or wall using the provided hardware as shown. **(Image 1.5)**

Product specifications and dimensions are approximate and for informational purposes only. Variations may occur due to design or manufacturing adjustments. For exact measurements, please confirm with our customer service before ordering. PWI reserves the right to modify specifications without notice.



ULTRALITE Tie Rod Jib Crane Systems



- Using the supplied drawings measure up to find the location of the upper hinge on the column or wall. Make sure that the holes are as level as possible. **(Image 1.6)**

(If you need drawings of your system, contact your representative or PWI at pwiworks.com)

- Repeat steps 1.3 – 1.5 but now with the upper hinge.
- Before attaching the Jib Beam, screw both Thread Clevis's on either side of the Tie Rod until the rod is roughly flush with the inside of the pin and the pins are aligned. **(Images 1.8A & 1.8B)**

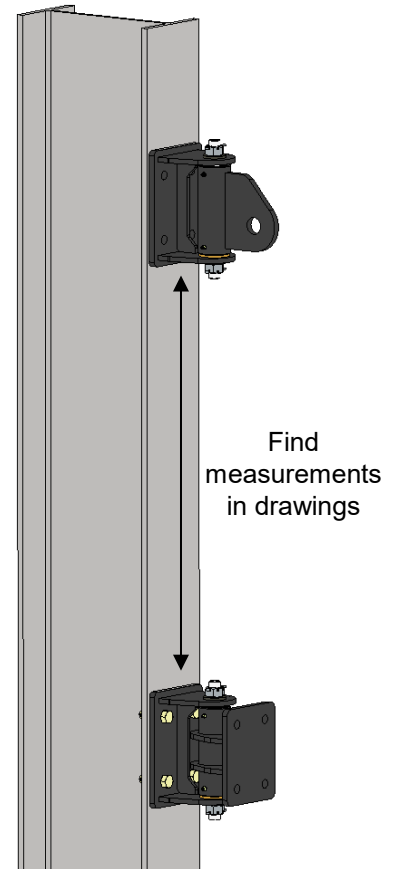

Image 1.6 Both Hinges

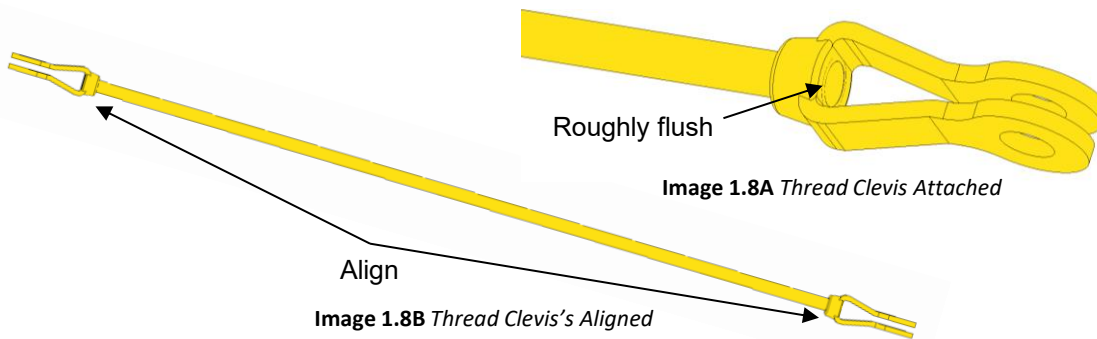

Image 1.8A Thread Clevis Attached

Image 1.8B Thread Clevis's Aligned

- If your Tie Rod is long enough to require a Turnbuckle, thread the rods about halfway through each thread into the turnbuckle as shown. Ensure the Thread Clevis's are still aligned. **(Images 1.9A & 1.9B)**

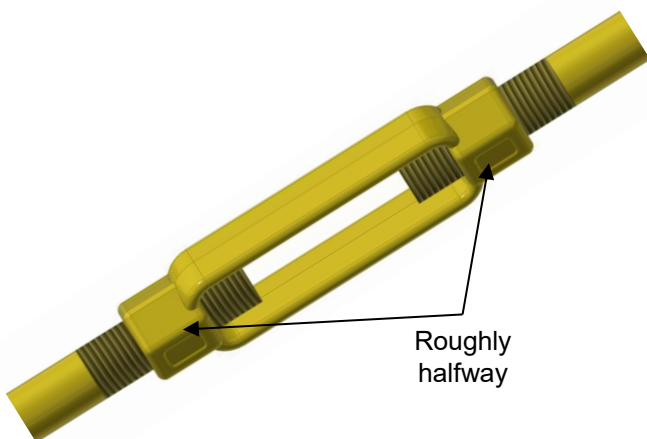

Image 1.9A Turnbuckle

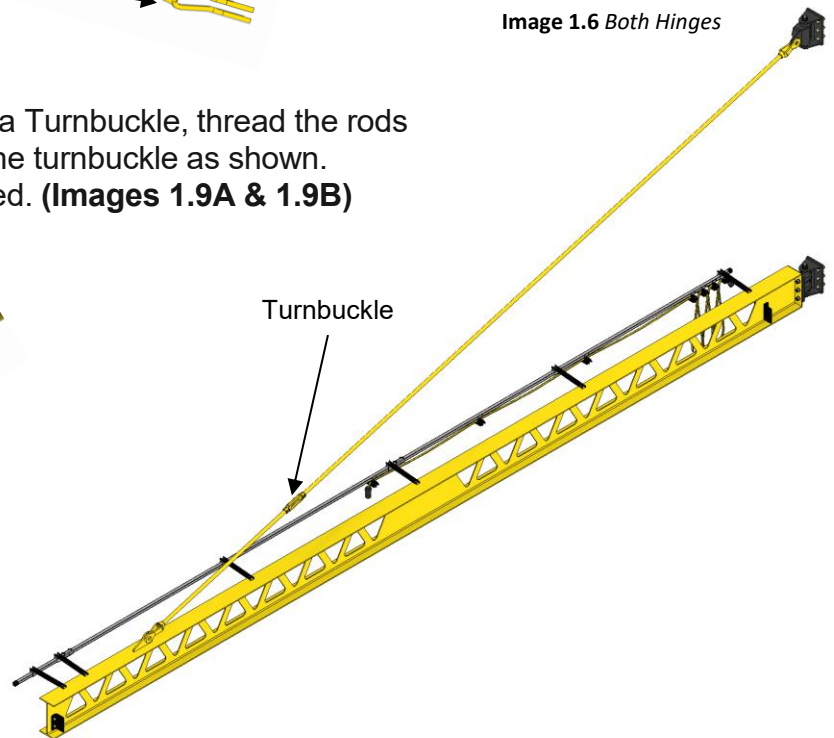

Image 1.9B Large Jib with Turnbuckle

Product specifications and dimensions are approximate and for informational purposes only. Variations may occur due to design or manufacturing adjustments. For exact measurements, please confirm with our customer service before ordering. PWI reserves the right to modify specifications without notice.



ULTRALITE Tie Rod Jib Crane Systems



To perform these next steps, requires more than one person.

10. Once the holes are drilled and the upper hinge is mounted to the structure you are now ready to support the horizontal beam with welded tie rod bracket facing up. Raise the jib beam safely into position to bolt it to the hinge. (Images 1.10A & 1.10B)

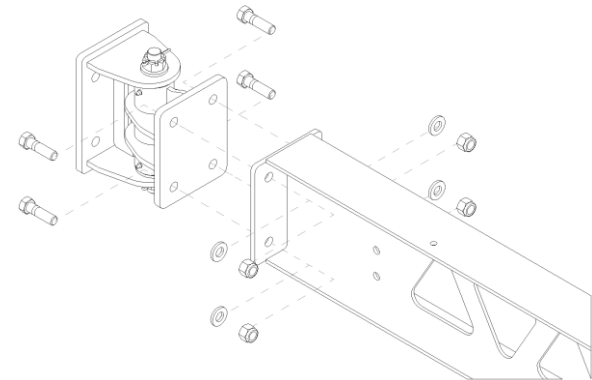

Image 1.10B Jib to Lower Hinge

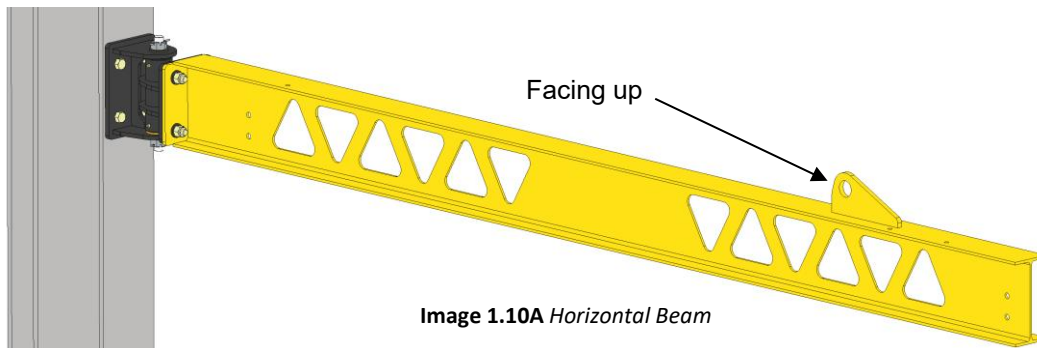

Image 1.10A Horizontal Beam

11. While still supporting the Jib Beam, attach the Tie Rod first to the top hinge and then to the Jib Beam using the hardware provided as shown. (Image 1.10A & 1.10B)

12. Double check and tighten all hardware attached.

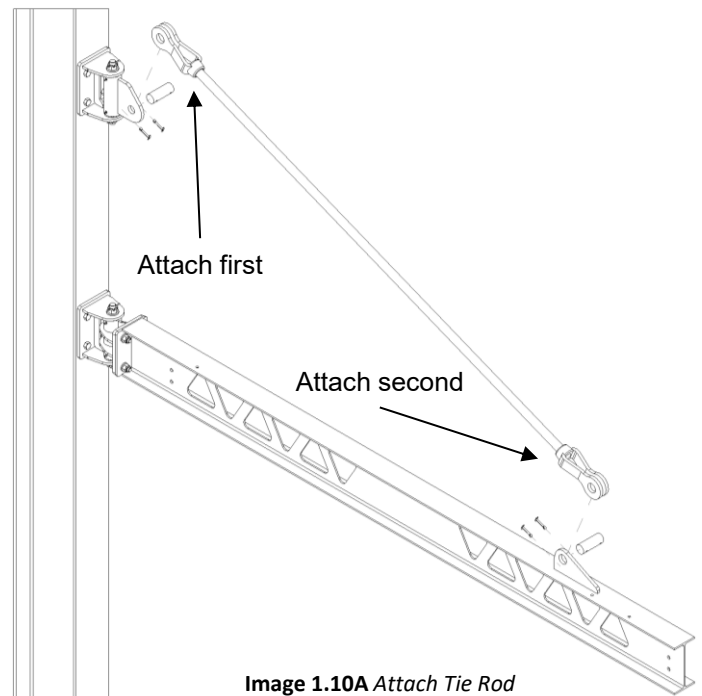

Image 1.10A Attach Tie Rod

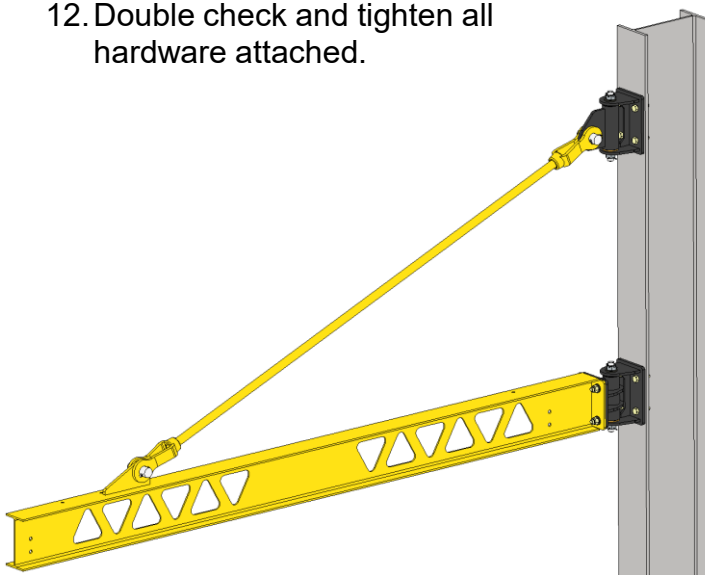

Image 1.10B Tie Rod Attached

Product specifications and dimensions are approximate and for informational purposes only. Variations may occur due to design or manufacturing adjustments. For exact measurements, please confirm with our customer service before ordering. PWI reserves the right to modify specifications without notice.



ULTRALITE Tie Rod Jib Crane Systems



13. If your Jib Crane came with a Jib rotation stop kit, mount it on the beam using the U-Bolts and provided hardware as shown so that the rubber bumpers line up with the middle of the Jib Crane. **(Images 1.13A & 1.13B)**

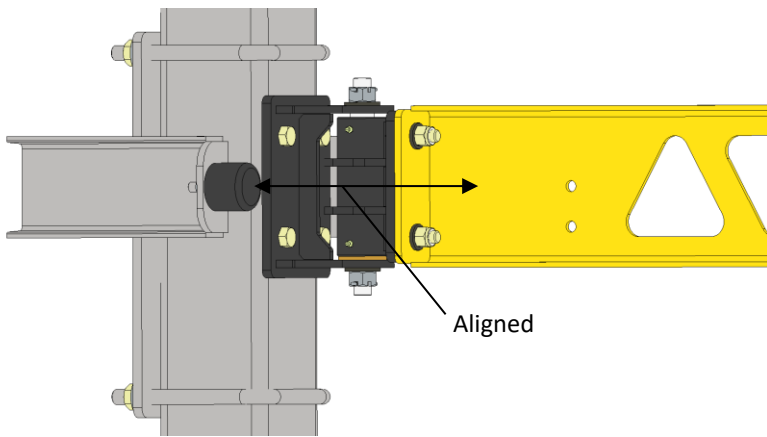

Image 1.13A Rotation Stop Aligned

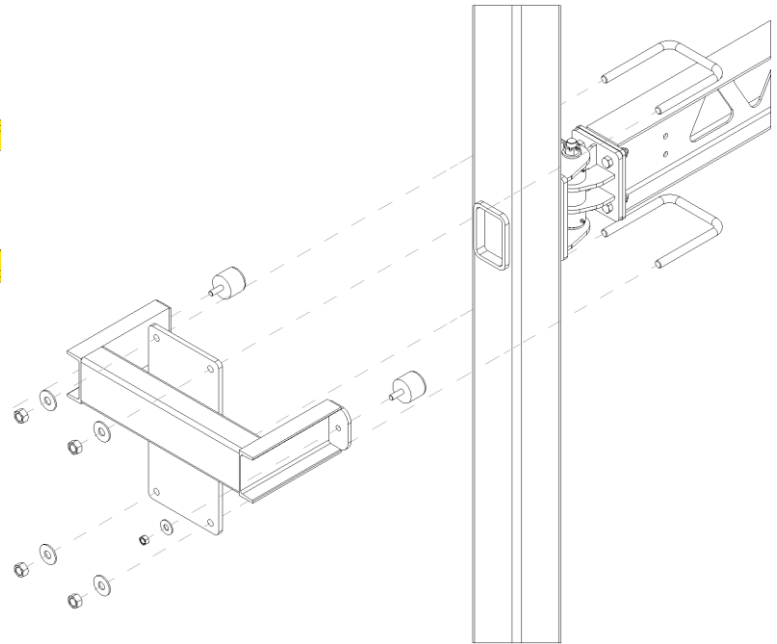

Image 1.13B Rotation Stop Exploded View

Step 2. Installing the Trolley on the Jib Beam

1. Now that your Jib Crane is securely mounted, slide on your trolley and clamp vice grips on either side of the trolley to temporarily secure it. **(Image 2.1)**
2. Once your trolley is secured, mount the End Stops on either side of the Jib Beam using the hardware provided as shown. Make sure the stopping plate is facing inwards for both sides. Mount your hoist on the trolley while it's still clamped. Unclamp your trolley once End Stops and hoist are installed. **(Images 2.2A & 2.2B on next page)**

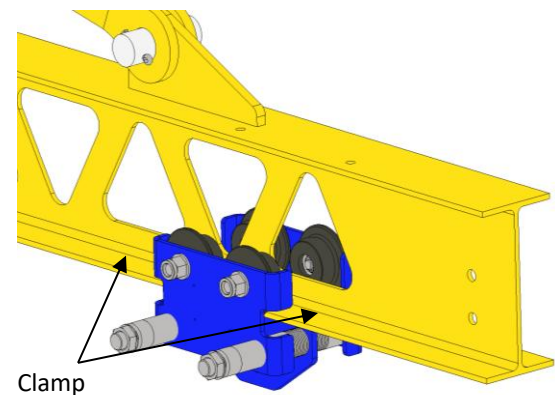

Image 2.1 Trolley Mounted

Product specifications and dimensions are approximate and for informational purposes only. Variations may occur due to design or manufacturing adjustments. For exact measurements, please confirm with our customer service before ordering. PWI reserves the right to modify specifications without notice.



ULTRALITE Tie Rod Jib Crane Systems

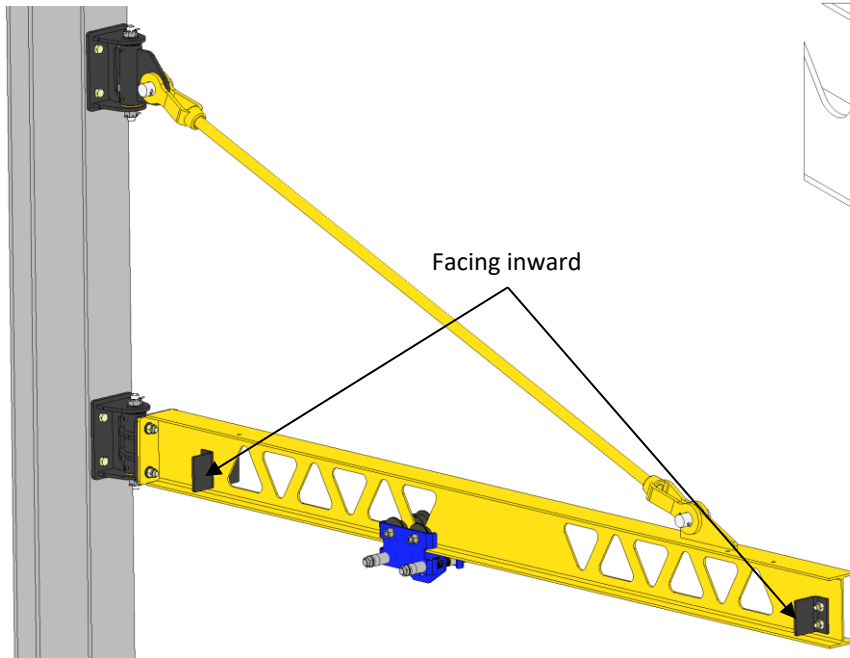

Image 2.2A End Stops Mounted

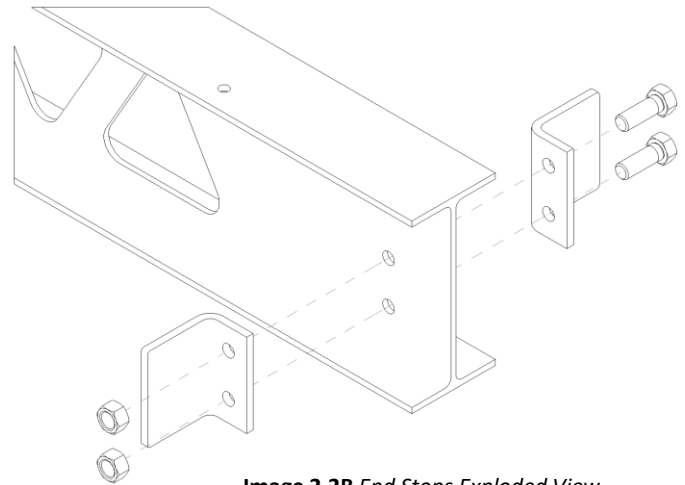

Image 2.2B End Stops Exploded View

Step 3. Hoist Electrification Installation on Your Jib

1. Bolt a Festoon Bracket in each of the mounting holes with the provided hardware as shown. Make sure each bracket is perpendicular to the Jib Beam. **(Image 3.1)**
2. Take your Festoon Rail and Hangers and slide on the Hangers to their approximate spacing along the rail. **(Image 3.2)**

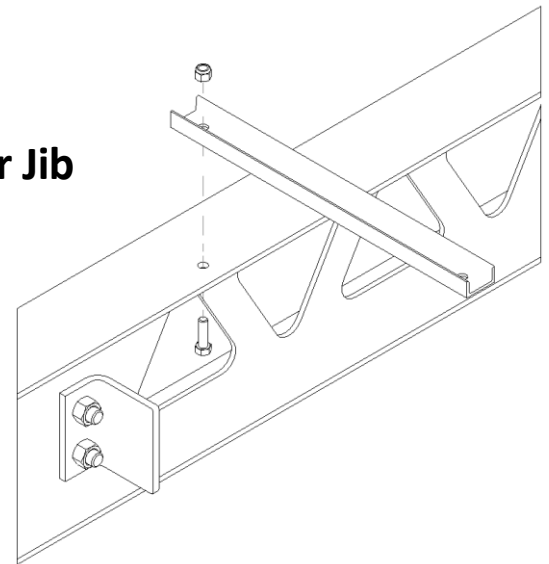

Image 3.1 Festoon Bracket

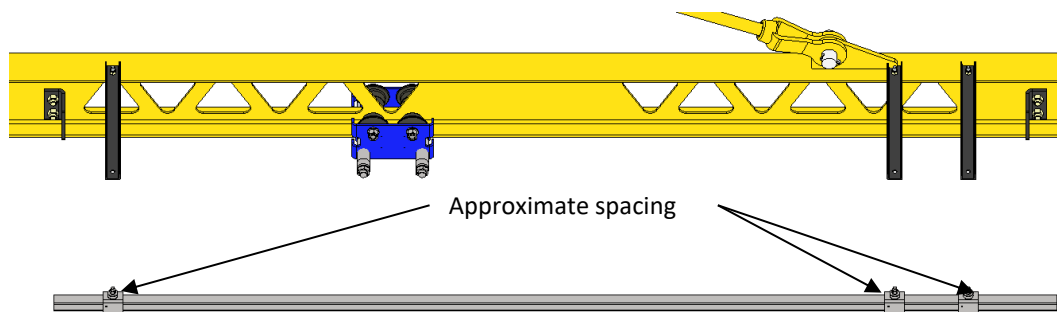

Image 3.2 Hangers on Rail

Product specifications and dimensions are approximate and for informational purposes only. Variations may occur due to design or manufacturing adjustments. For exact measurements, please confirm with our customer service before ordering. PWI reserves the right to modify specifications without notice.



ULTRALITE Tie Rod Jib Crane Systems



3. Attach each Hanger to each Bracket using the hardware provided as shown. **(Image 3.3)**

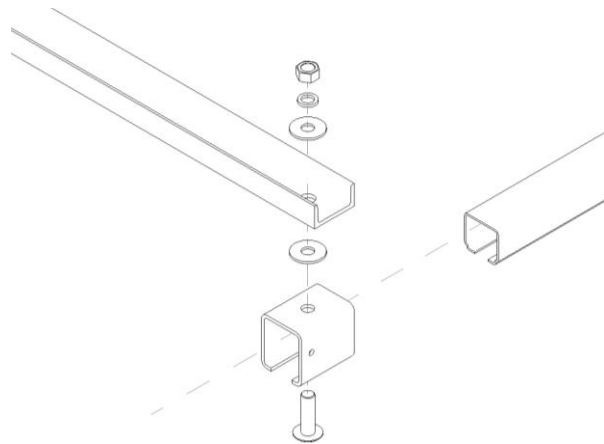

Image 3.3 Hanger Exploded View

4. Slide each bracket and trolley onto the Festoon rail. The bracket is mounted near the end of the rail while each trolley is placed roughly 60" from each other before attaching the cable. **(Image 3.4)**

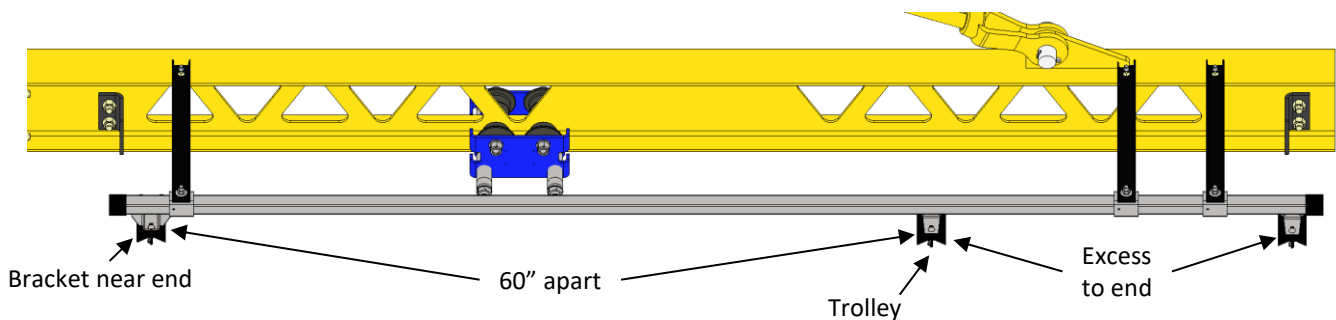

Image 3.4 Trolley Mounting & Spacing

5. Unclamp each clamp on the bracket and trolleys, slide the festoon cable in between the clamps, and tighten the clamps back up once the cable is inserted. Be sure not to over tighten as this could damage the festoon wire. **(Image 3.5)**

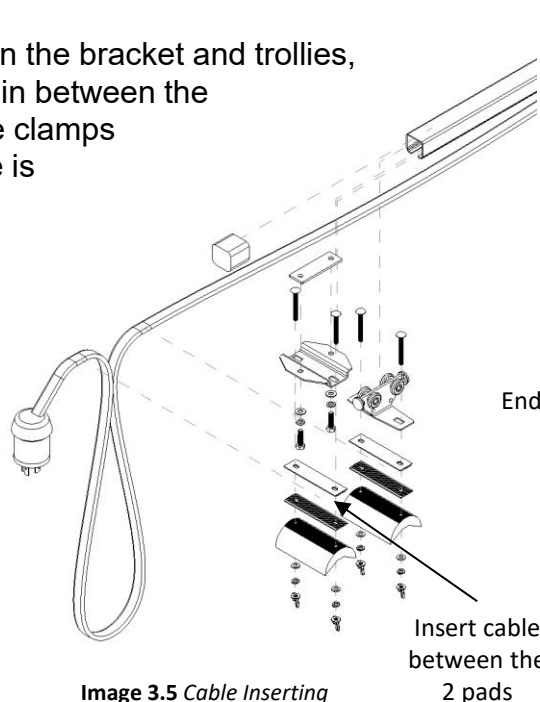

Image 3.5 Cable Inserting

6. Put on the end caps and plug in your hoist! **(Image 3.6)**

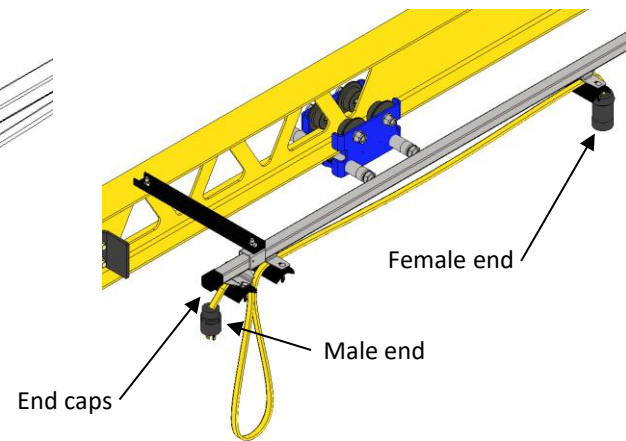

Image 3.6 Festoon Final View

Product specifications and dimensions are approximate and for informational purposes only. Variations may occur due to design or manufacturing adjustments. For exact measurements, please confirm with our customer service before ordering. PWI reserves the right to modify specifications without notice.





CRANE OPERATOR INSTRUCTIONS

1. **General:** At PWI, safety is our top priority, especially when operating overhead cranes and jib cranes in work areas where personnel are present. Proper training and attention to detail are essential to prevent accidents and ensure safe operation. These guidelines are designed to supplement your existing safety protocols and OSHA regulations, not replace them. Reviewing this information will help operators better understand safe practices, protecting both employees and equipment on the job site. It is important to note that these guidelines serve as recommendations for crane operators. Employers are responsible for ensuring their teams are aware of and comply with all relevant federal, state, and local regulations and that operators are adequately trained.
2. **Operator Qualifications:** Safe crane operation demands skill, attentiveness, and a strong commitment to safety. All crane operators should meet the following criteria:
 - A. **Language Proficiency:** The operator must understand the appropriate language and be able to read safety and instruction materials.
 - B. **Legal Age:** Operators must meet the minimum legal age requirement for operating such equipment.
 - C. **Health and Fitness:** Operators must have sufficient vision and hearing (corrected if necessary) and must not suffer from health conditions, such as heart issues, that could impair performance.
 - D. **Training and Knowledge:** Operators must have read and understood all operating instructions, completed proper training, and demonstrated their knowledge through practical application.
3. **Operating the Jib Crane Boom:**
 - A. Before using the boom, ensure the hook is positioned high enough to avoid obstructions.
 - B. Align the jib boom directly over the load before attempting to lift.
 - C. Operate the boom gradually, starting slowly and increasing speed smoothly. As the boom approaches the stopping point, reduce speed to ensure a controlled stop.
4. **Operating the Trolley:**
 - A. Position the hoist directly over the load before lifting. Ensure all slack in the slings is taken up.
 - B. Avoid starting to lift until the hoist is properly centered to prevent the load from swinging.
 - C. Start trolley motion at a slow speed and decelerate gradually when nearing the destination.
5. **Hoist Operation:**
 - A. Refer to the operating manual specific to your lifting equipment for detailed instructions. Always follow the manufacturer's recommendations and guidelines for safe operation.



Product specifications and dimensions are approximate and for informational purposes only. Variations may occur due to design or manufacturing adjustments. For exact measurements, please confirm with our customer service before ordering. PWI reserves the right to modify specifications without notice.



ULTRALITE Tie Rod Jib Crane Systems



6. **Know Your Crane:** Crane operators must be familiar with the key components of a crane and possess a thorough understanding of crane control functions and movements. Operators must know the location and correct operation of the main disconnecting means for all power to crane attachments.
7. **Responsibility:** Crane operators bear direct responsibility for the safe operation of the crane. If there is any doubt regarding ****safety****, the operator must stop the crane and refuse to handle loads until either:
 - A. Safety is ensured, or
 - B. The operator is directed to proceed by a supervisor, who then assumes full responsibility for the safety of the lift.
8. **Riding Policy:** Never allow anyone to ride on the hook or a load.
9. **Inspection:** At the start of each shift, test crane movements and all attachments. If an issue is identified, report it immediately to a supervisor, and ensure corrective action is taken before operating.
10. **Operating:** A skilled crane operator ensures smooth and controlled crane operation. Adhere to the following guidelines for safe and efficient crane handling:
 - A. Move the crane smoothly to avoid abrupt or jerky load movements. Remove slack from slings and hoisting ropes before lifting.
 - B. Position the crane directly over the load before lifting to minimize swinging. Avoid swinging loads to reach areas not directly beneath the crane.
 - C. Keep crane-hoisting ropes vertical. Cranes must not be used for side pulls.
 - D. Ensure the area around the load is clear, and everyone is aware of the movement.
 - E. Never exceed the rated load capacity of the crane, slings, or lifting devices.
 - F. Confirm slings, chains, or lifting devices are fully seated in the hook saddle with the latch closed (if equipped).
 - G. Verify the load and/or block is high enough to clear obstructions when moving the boom or trolley.
 - H. Do not leave a suspended load unattended. When holding a load, keep the power on and stay at the controls with the load positioned as low as possible.
 - I. Do not lift with loose sling hooks. Store unused hooks securely or switch to an appropriate sling.
 - J. Remove all slings or cables from crane hooks when not in use to prevent snagging.
 - K. Avoid carrying loads or blocks over personnel. Exercise additional caution with magnets or vacuum devices, as load failure can occur.
 - L. Operator Procedure when they leave the crane:
 - a. Raise hooks to an intermediate position.
 - b. Park the crane at a designated location.
 - c. Turn all controls off.
 - d. Shut off the main switch.
 - e. Visually inspect the area before leaving.



Product specifications and dimensions are approximate and for informational purposes only. Variations may occur due to design or manufacturing adjustments. For exact measurements, please confirm with our customer service before ordering. PWI reserves the right to modify specifications without notice.



ULTRALITE Tie Rod Jib Crane Systems



- 11. Emergency Procedures:** In emergencies or during maintenance, display warning signs and lock the main switch in the “off” position. This applies regardless of who is performing the task.
- 12. End Stops:** Contact end stops cautiously. Ensure the safety of people below and communicate clearly with other crane operators in the area.
- 13. Safety Features:** All safety mechanisms and features provided by PWI are essential for crane operation. Do not disable or remove any safety features. Any such actions void all warranties.

ANY SAFETY FEATURES AND MECHANISMS BUILT IN OR OTHERWISE PROVIDED WITH THE CRANE BY PWI ARE REQUIRED FOR THE SAFE OPERATION OF THE CRANE. DO NOT, UNDER ANY CIRCUMSTANCES, REMOVE OR OTHERWISE IMPAIR OR DISABLE THE PROPER FUNCTIONING OF ANY CRANE SAFETY MECHANISMS OR FEATURES BUILT-IN OR OTHERWISE PROVIDED BY PWI FOR SAFE OPERATION OF THE CRANE. ANY REMOVAL, IMPAIRMENT OR DISABLING OF ANY SUCH SAFETY MECHANISMS OR FEATURES OR OTHER USE OR OPERATION OF THE CRANE WITHOUT THE COMPLETE AND PROPER FUNCTIONING OF ANY SUCH SAFETY MECHANISMS OR FEATURES AUTOMATICALLY AND IMMEDIATELY VOIDS ANY AND ALL EXPRESS AND IMPLIED WARRANTIES OF ANY KIND OR NATURE.

➡ **TIP:** Do not throw away this manual: the maintenance schedule is included. Keep Packing List, Installation Manual, General Arrangement Drawing, and any other inserts filed together in a safe place.



Product specifications and dimensions are approximate and for informational purposes only. Variations may occur due to design or manufacturing adjustments. For exact measurements, please confirm with our customer service before ordering. PWI reserves the right to modify specifications without notice.





GENERAL WARRANTY

This warranty will not apply to any product that has been repaired or altered outside of PWI manufacturing plant, or without specific instructions from PWI to make alterations. PWI will in no case, allow or offer reimbursement for outside sources to perform repairs or make alterations to product in reference. If the product has (in PWI's judgment), had alterations made which adversely affect its serviceability or was subject to misuse, negligence, accident, or operated contrary to instructions or common practice, warranty shall be considered void.

Defective items will be repaired or replaced and returned to PWI at the cost of the owner. If PWI, at its discretion, finds the warranty claims to be justifiable, PWI will compensate by means of replacing or repairing faulty products or components free of charge. The sole liability of PWI for warranty claims is limited to those here. In no event will PWI be liable for damages in excess of the original sale price of the defective product, or for any consequential damages, nor will PWI be liable for any special or other work done unless specifically agreed to in writing. This warranty does not include or apply to fire, natural disasters, or other Acts of God.

Should the warrantee destroy, intentionally or not, any part of the warranted product, or any evidence concerning the origin of an alleged defect, or try to conceal evidence of causation, this warranty is cancelled, and warrantee will have no claim against PWI whatsoever.

This warranty does not cover coatings on any PWI products including paint, powder-coat, zinc, or galvanized coatings. Coating life can vary greatly based on the ambient environment your PWI product is installed in, which is simply out of the manufacturer's control. Touch-up painting or coating repair (after initial installation by PWI or customer) shall be the responsibility of the owner, unless specifically guaranteed in writing on project quotation.

Any interpretation of this warranty shall be done in common pleas court in Indianapolis under Indiana law.

ALL OTHER REPRESENTATIONS, EXPRESS OR IMPLIED, WARRANTY, OR LIABILITY RELATING TO THE CONDITION OR USE OF THE PRODUCT ARE SPECIFICALLY, DISAVOWED, AND IN NO EVENT SHALL PWI BE LIABLE TO BUYER, OR ANY THIRD PARTY, FOR ANY DIRECT OR INDIRECT CONSEQUENTIAL OR INCIDENTAL DAMAGES



Product specifications and dimensions are approximate and for informational purposes only. Variations may occur due to design or manufacturing adjustments. For exact measurements, please confirm with our customer service before ordering. PWI reserves the right to modify specifications without notice.



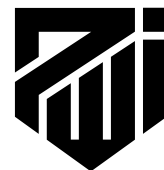

LIMITED WARRANTY

STRUCTURAL: 3-Year (36 Month) Parts & Workmanship Warranty

Structural items include but are not limited to columns, headers, runways, and other stationary components of this PWI jib crane.

Unless otherwise specified, PWI guarantees that the structure of this product is free from material defects in design, materials, and workmanship under normal use, proper maintenance, and service. A corrosive or abrasive atmosphere is not to be considered a normal atmosphere.

This warranty is strictly limited to 36 months for single shift operation or 6,000 hours after installation, or 38 months after shipment, whichever is shorter. Within ten days after defect is found, warrantee must deliver a written notice to PWI. All requested warranty information must be received promptly by PWI in no more than 5 business days.

MECHANICAL: 1 Year (12 Month) Parts & Workmanship Warranty

Mechanical items include but are not limited to all types of Overhead Cranes, and other non-stationary PWI products that are designed for specific functional operation.

Unless otherwise specified, PWI guarantees that this mechanical product is free from material defects in design and workmanship under normal use, proper maintenance, and service.

This warranty is strictly limited to 12 months for single shift operation or 2,000 hours after installation, or 14 months after shipment, whichever is shorter. Within ten days after defect is found, warrantee must deliver a written notice to PWI. All requested warranty information must be received promptly by PWI in no more than 5 business days.

All standard non-engineered products including but not limited to hoists, trolleys, wheels, gearmotors, controls, and safety products, will fall under the default warranty of that specific manufacturer.



Product specifications and dimensions are approximate and for informational purposes only. Variations may occur due to design or manufacturing adjustments. For exact measurements, please confirm with our customer service before ordering. PWI reserves the right to modify specifications without notice.





PERIODIC INSPECTION AND LUBRICATION RECOMMENDATIONS

The following is a checklist to be followed in performing periodic inspections and preventative maintenance on PWI Crane Systems. It is intended that this checklist be supplemented with any additional instruction sheets and maintenance manuals sent with each job.

The frequency of inspection and lubrication recommendations presented herein is based upon normal operating conditions of one complete handling cycle every 10 minutes throughout a 40-hour week. If the actual duty cycle of a particular unit is greater or less than this, the inspections and lubrications should be performed more frequently or less frequently in proportion.

Each industry has conditions peculiar to it, which may cause wear of certain parts. The tabulation given is only general and may be supplemented by an individual maintenance department program to meet its own particular requirements. Particular attention should be given to corrosive conditions, excessive vibrations, extreme ambient temperature variations, and rough handling conditions.

Questions regarding damaged, worn or cracked equipment components should be directed to the PWI Inside Sales Department at 574-646-2015.

The recommendations contained herein are to be supplemented by any vendor instructions, which are included in this manual.

Power should be off and locked when performing maintenance.

Please check the state and local code manuals in your area to ensure compliance

Parts: Your system is custom designed for your space. The drawings that you received are specific to your system. PWI has copies of your drawings in a file under the company name or the name of the purchaser. If you require replacement parts, please call or email PWI and we will be glad to assist you in getting what you need. parts@pwiworks.com





RUNWAYS & SUPPORT STEEL

COMPONENT	MAINTENANCE	FREQUENCY
Header-Column Hardware	Check for loose bolts & cracked fittings. Check for full compression of lock washer. Bolt should be tightened to manufacturer's specifications.	Every 1,000 hours or 6 months
Header-Runway Hardware	Check for loose bolts & cracked fittings. Check for full compression of lock washer. Bolt should be tightened to manufacturer's specifications.	Every 1,000 hours or 6 months
Column Anchoring	Check for loose bolts & cracked fittings.	Every 1,000 hours or 6 months
Sway Brace Connection (If used)	Check for loose bolts & cracked fittings.	Every 1,000 hours or 6 months
Runway	Check for runway wear or damage.	Every 2,000 hours or yearly
Joints	Check for loose or worn hardware or if welded type, for incipient cracks. Check for runway alignment and that wheel rolling surface is flush.	Every 2,000 hours or yearly
End Stops	Check for loose bolts and for incipient cracks.	Every 2,000 hours or yearly
Paint	Clean periodically and repaint where corrosion is present.	Every 2,000 hours or yearly



Product specifications and dimensions are approximate and for informational purposes only. Variations may occur due to design or manufacturing adjustments. For exact measurements, please confirm with our customer service before ordering. PWI reserves the right to modify specifications without notice.





BRIDGE

COMPONENT	MAINTENANCE	FREQUENCY
Controls	Check for burned contacts, broken shading coils, worn or cracked arc barriers, auxiliary contacts, and proper seating.	Every 1,000 hours or 6 months
Push Buttons & Pendant	Check contacts. Tighten leads. Check for sticking buttons. Check ground wire continuity. Check pendant cable top and bottom for broken wires. Check strain chain to see that any pulling force is not put on pendant cables.	Every 1,000 hours or 6 months
Bridge Girder	Check Bridge Girder for wear or damage.	Every 2,000 hours or yearly
End Stops	Check for loose bolts and for incipient cracks.	Every 2,000 hours or yearly
Paint	Clean periodically and repaint where corrosion is present.	Every 2,000 hours or yearly

END TRUCK, & HOIST TROLLEY

COMPONENT	MAINTENANCE	FREQUENCY
Structural Frame & Load Bars	Check for incipient cracks in welds and castings. Check for loose bolts.	Every 2,000 hours or yearly
Suspension Point	Check for wear and loose or missing screws or pins.	Every 150 hours or 1 month
Wheels & Guide Rollers	Check for loose wheel bearings. Check wheels for proper contact and tracking on rail. Check wheel diameter for wear (Replace when 1/4" under original diameter). Check axle nuts for tightness.	Every 500 hours or 3 months



Product specifications and dimensions are approximate and for informational purposes only. Variations may occur due to design or manufacturing adjustments. For exact measurements, please confirm with our customer service before ordering. PWI reserves the right to modify specifications without notice.





FESTOON ELECTRIFICATION

COMPONENT	MAINTENANCE	FREQUENCY
Connections	Check connections to ensure no wires are worn and no conductors are exposed.	Every 150 hours or 1 month
Insulation	Check to ensure no damage is visible.	Every 2,000 hours or yearly
Complete System	In environments that are subject to considerable buildup of dust, especially conductive dust, remove this dust by brushing.	Every 2,000 hours or yearly

STARKE ELECTROTRACK

COMPONENT	MAINTENANCE	FREQUENCY
Rail	Check for corrosion, bowing, or sagging. Check alignment at moving gaps. Realign if necessary.	Every 2,000 hours or yearly
Couplings	Check bolt or screw tightness. Check for corroded contact surfaces.	Every 2,000 hours or yearly
Supports	Check for loose bolts and/or screws and bent brackets.	Every 2,000 hours or yearly
Insulators	Check for loose bolts, sheared support ears, current carrying deposits on surface.	Every 2,000 hours or yearly
Rail Covering	Check for accidental abrasion and peeled covering.	Every 2,000 hours or yearly
Current Taps	Check bolt and terminal screw tightness. Check for corroded contact surface.	Every 2,000 hours or yearly
Ground	Check for ground continuity. Check at load side of disconnect switch (current off), with meg-ohm tester, for overall system insulation resistance.	Every 2,000 hours or yearly
Collectors	Check for worn shoes. Check flexible leads from wheel clevis pigtail or slide shoe shaft. Check tightness of lead connections. Check for cracked insulators. Replace if necessary.	Every 750 hours or 4 months

HOIST (Refer to Hoist Manufacturer)



Product specifications and dimensions are approximate and for informational purposes only. Variations may occur due to design or manufacturing adjustments. For exact measurements, please confirm with our customer service before ordering. PWI reserves the right to modify specifications without notice.



