

# PWI MEZZANINE INSTALLATION GUIDE

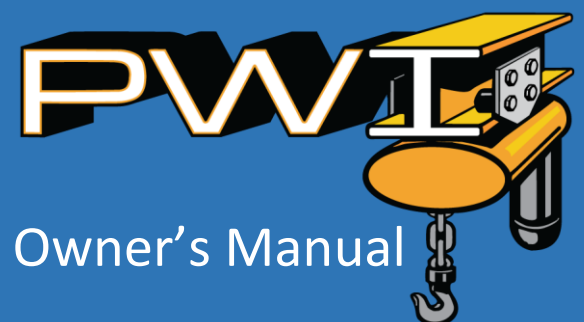

# TABLE OF CONTENTS

Safety & Pre-Installation Checklist.....	2
Determining the Location .....	3
Steps of Installation .....	3
Layout of Structure .....	4
Column Anchors .....	5
Installing the Headers .....	6
Installing the Crossmembers and Bracing .....	7&8
Preliminary Toe-kick and Posts .....	9
Metal Decking .....	10
Installing the Flooring Surface .....	12
Final Railing Assembly .....	13
Stairways & Gates .....	15
Warranty .....	16

## Congratulations!

The PWI mezzanine structure you have purchased is the result of years of engineering & design, and onsite assembly by our own installation crews. Long before this manual existed PWI had been building mezzanines across the USA. Our mezzanines are built with years of experience, and we want you to know that we have put all that knowledge into what we have built for you. Please remember that our #1 goal is that you will have a successful installation.

**Before you begin.** Read the instructions carefully, from beginning to end, and follow the proper sequence. On the next page you'll find a safety section and general checklist that you should read before starting your installation.

Thank you from the entire staff at PWI.

PWI  
7930 W 1000 N  
Nappanee IN, 46550

[www.pwiworks.com](http://www.pwiworks.com)  
Phone 574-646-2015  
Email- [sales@pwiworks.com](mailto:sales@pwiworks.com)

## General Safety

Safety comes first when unloading and assembling your mezzanine structure. Many of the components are heavy and require lifting tools to move and set them in place. Make sure the equipment you choose to support and lift each piece is capable of the task with extra capacity to do the job so that you do not end up in a dangerous situation.

Check any lifting fixtures for damage or wear that could lead to severe injury or death.

This manual assumes that you have performed any foundation work ahead of placing your mezzanine columns in their proper location. Failure to provide the proper footing depth and width based on your column loads can result in failure of the floor structure supporting your mezzanine. Please call PWI if you are unsure of the requirements for your mezzanine.

### Pre-Installation:

- Check your shipment for the correct components and hardware. Your shipment should include shipping sheets that were checked off by our team
- Check your shipment for drawings for layout and installation of components
- Clear the area as much as possible of items that could be damaged or create hazards during the installation. When assembling near electrical panels be aware of any regulations regarding perimeters required around those objects
- Marking pen and measuring tapes
- Hilti nailer tool (see page 9)
- Hammer Drill and bits for anchors
- Measure twice and cut once
- Should you have any technical questions, or feel you have defective components or missing items, call us immediately. We will be glad to assist you.

- Step 1 – Laying out your structure
- Step 2 - Anchor Installation
- Step 3 – Install header I-beams
- Step 4 – Install crossmember I-beams
- Step 5 – Install Bracing
- Step 6 – Install Railing Toe-kick & Posts
- Step 7 – Decking installation
- Step 8 – Wood Flooring installation
- Step 9 – Horizontal Railing

## Determining and marking the exact location

After identifying the general location for the PWI mezzanine structure it is time to lay out the column locations. By making marks on the floor to verify that the column placement as shown on your drawings will fit the area you have selected, you will then be confident that the mezzanine installation will go smoothly. Some time spent in this operation can save you a lot of time later.

**Step 1. Laying Out Your Structure.** Using tape or black marker, mark the column center on the floor for each column as shown on the print. Verify with a string that the column lines are straight. Verify with a tape measure that the structure is “square”. Next, draw the general outline of your column’s **baseplate** on the floor. **IMPORTANT-** The tabs at the top of your columns are not centered on the columns. This is done so that the **header beam**, once installed, **IS centered** on the column. Make sure you place the header beam on the correct side of the column tab so that the header beam is centered on the column.

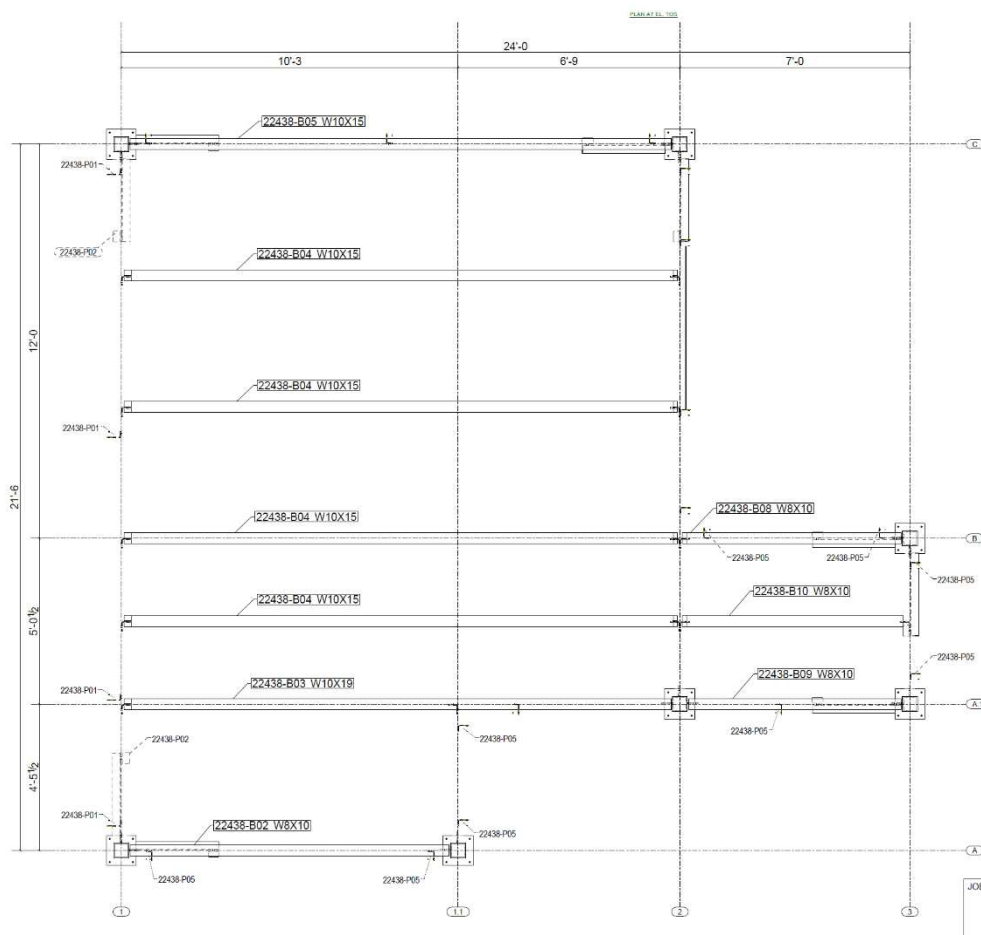

Column Placement Example Drawing



## Anchor Installation Instructions

**Step 2.** As each column is positioned check the orientation of the upper tabs. Once positioned correctly drill 2 anchor holes at each base plate and install (2) anchors for now. **IMPORTANT**-Columns are heavy and if they get bumped before they are temporarily anchored equipment or bystanders can be hurt or damaged. Get extra help and do what you can to prevent the columns from being tipped over until the 2 anchors are installed.

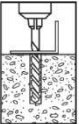
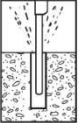
INSTALLATION STEPS

- 1.** Select a carbide drill bit with a diameter equal to the anchor diameter. Drill hole to any depth exceeding the desired embedment. See chart for minimum recommended embedment.
- 2.** Clean hole or continue drilling additional depth to accommodate drill fines.
- 3.** Assemble washer and nut, leaving top of stud exposed through nut. Drive anchor through material to be fastened until washer is flush to surface of material.
- 4.** Expand anchor by tightening nut 3-5 turns past the hand tight position, or to the specified torque requirement.

**\*\* ONLY FOR USE IN CONCRETE\*\***

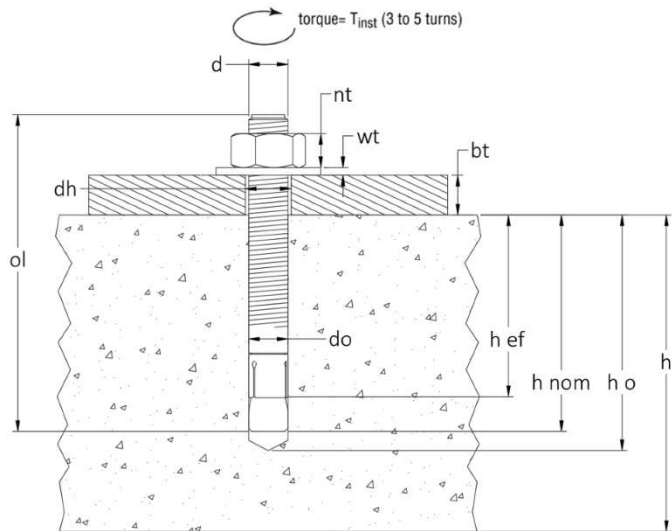

The above type of anchor is common for smaller mezzanine structures. Larger mezzanines may require other types of embedded anchors. Your mezzanine package should include the correct anchors for the mezzanine you purchased along with detailed instructions. For detailed information on anchors please refer to the sheet that was sent with your order.

(Remaining anchors can be added once the main structure, header beams, and cross members, are in place and the structure is determined to be correct)

**Step 3.** Installing **header I-beams** between columns as shown on your prints. Reference detailed instructions on hardware sizes and tightening of hardware sent with your order. Check that columns are plumb and use header hardware to hold columns plumb during assembly.

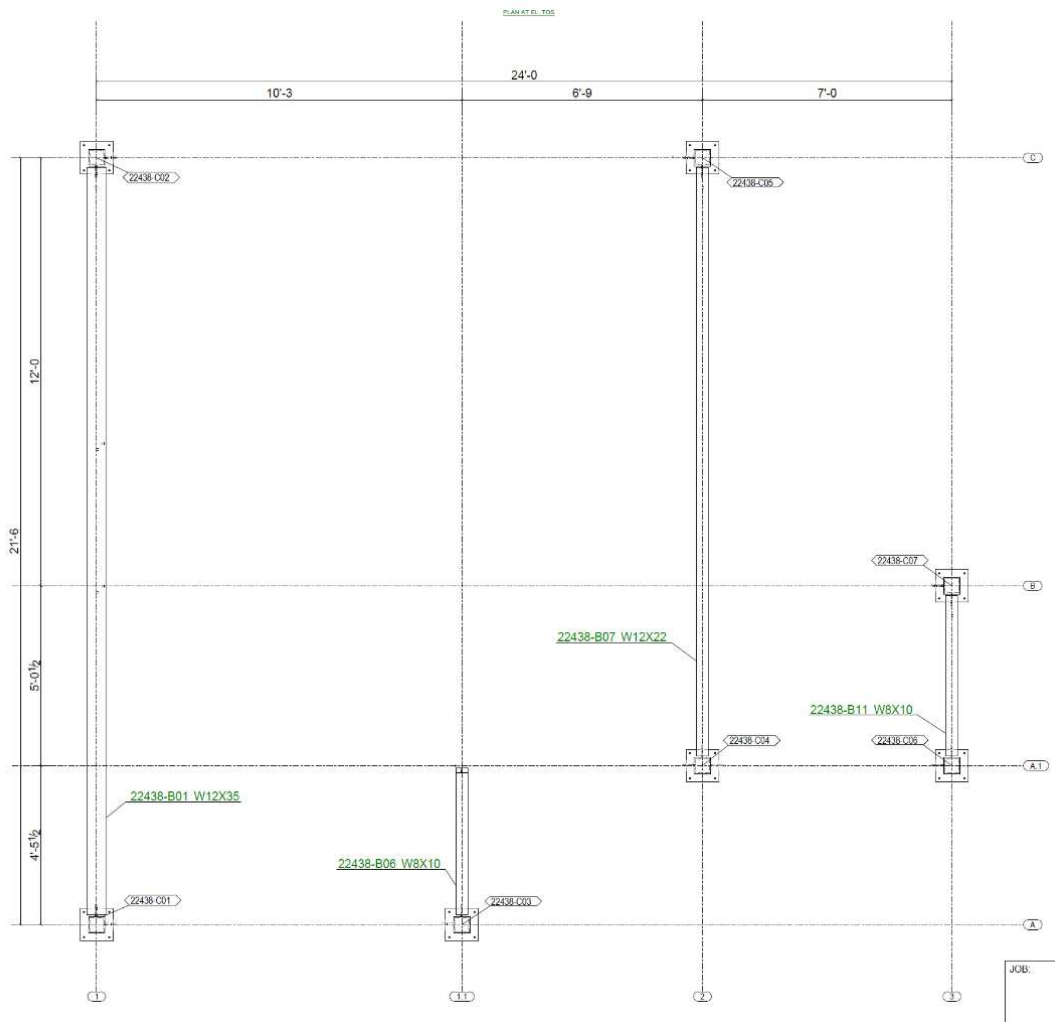

**Step 4.** Install the **crossmembers** between headers as shown on your prints. Be aware that your guardrail post black angle bracket may bolt to the mezzanine with the same hardware used to bolt the crossmember angle bracket to the header beam. Review your drawing to find out if some or all of your railing post brackets can be installed at the same time as the crossmember mounting bracket. Reference detailed instructions on hardware sizes and tightening of hardware sent with your order.

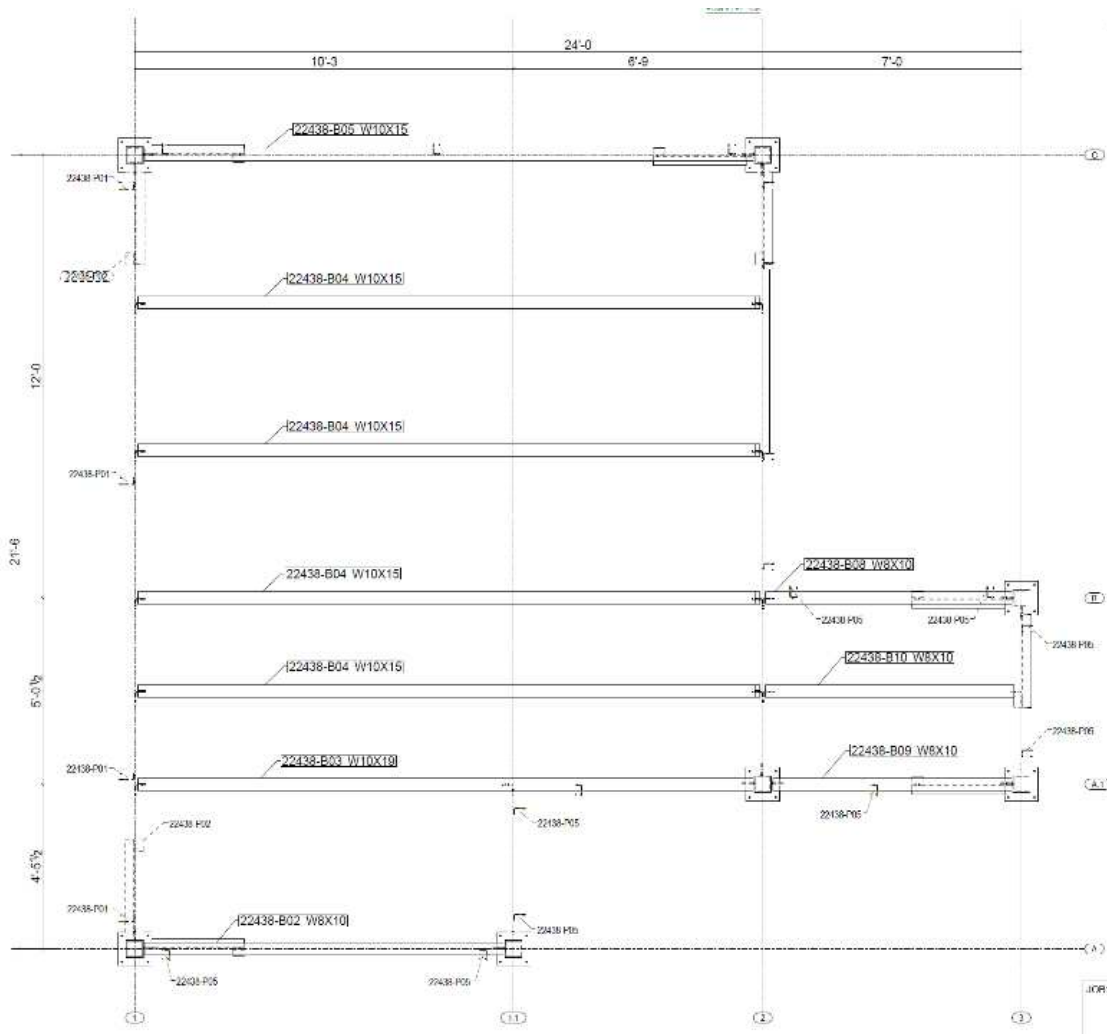



**Step 5. Bracing your mezzanine.** Depending on the design of your mezzanine and the surrounding structures you may have bracing as shown below. Knee bracing and “x” bracing are 2 examples of the type of bracing that may have come with your mezzanine order. Follow the detailed instructions supplied separately from this manual on the specifics of your bracing requirements.



**Step 6. Railing Posts and Toe-Kick.** Before installing the metal decking, you will need to install the railing kit posts (see step 8.) and the toe-kick onto the mezzanine. The main reason for completing this step now is because the toe-kick is designed **to go under the steel b-deck**. This gives a clean look to the edge of the mezzanine when viewed from the main floor. Installing the horizontal railings can be saved for later.



**Step 7. Decking installation.** The metal B-deck supplied with your mezzanine is designed to be fastened to the crossmembers of the mezzanine. The decking (when attached) does add stability to the mezzanine structure and cannot be loose on top of the crossmembers. Use the supplied fasteners to attach the decking to the crossmembers. See photo below of typical nail spacing pattern. (next page)

**(You may need to rent a Hilti DX 9-HSN Powder actuated decking tool.** This is required to attach the decking to the I-beam flanges. Powder shots and Hilti nails are packaged with your shipment.)



**B-Deck Orientation**  
 (For use with wood sheets, steel sheets, plywood)

**B-Deck-** The wider spaces between ribs of the decking is toward the top.

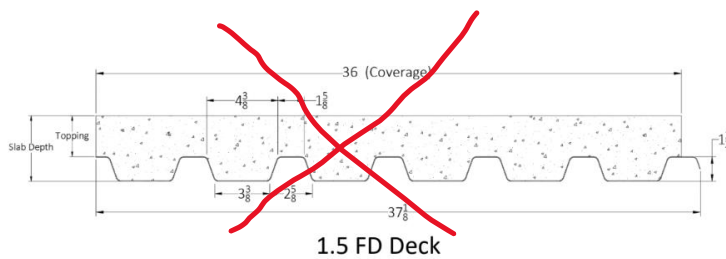

**Form Deck (F Deck)** is for use with **concrete floors only**. Note how the wider spaces between ribs are toward the bottom.



Hilti DX 9-HSN

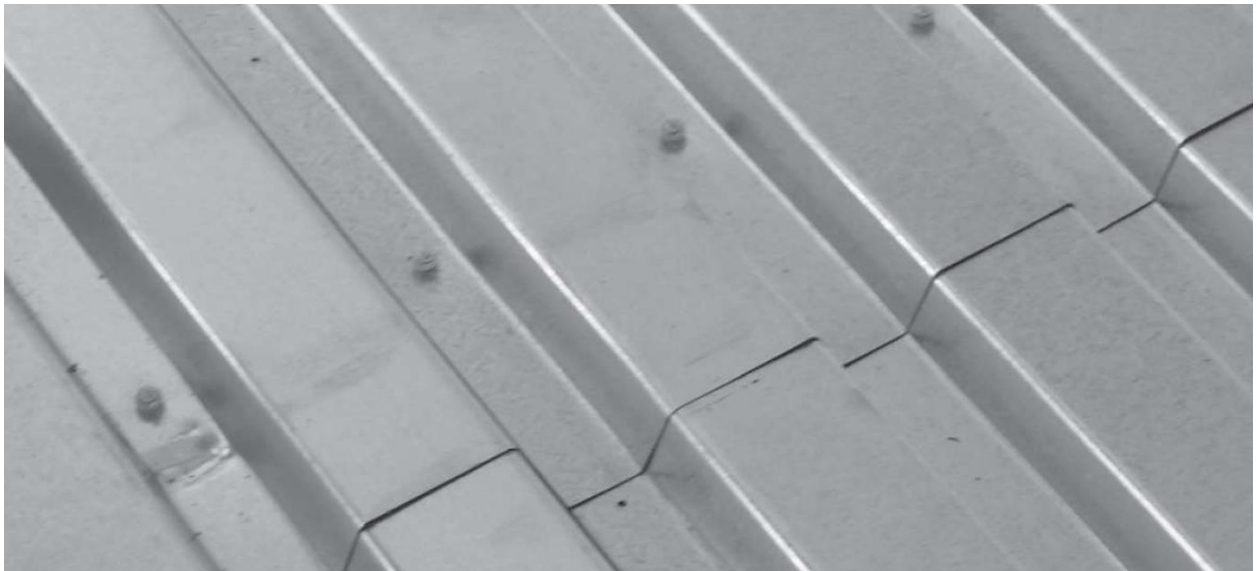

**Step 8. Wood flooring installation.** In most cases 4' x 8' x ¾" wood sheets create the floor surface of your mezzanine. Special screws designed to hold your sheets to the layer of B-Deck below are typically supplied with your mezzanine package if you purchased the wood sheets as part of your order. (If your order includes the ResinDek wood flooring product please go to <https://www.resindek.com/resources/installation-instructions> for installation instructions.)



Typical Screw Layout Example

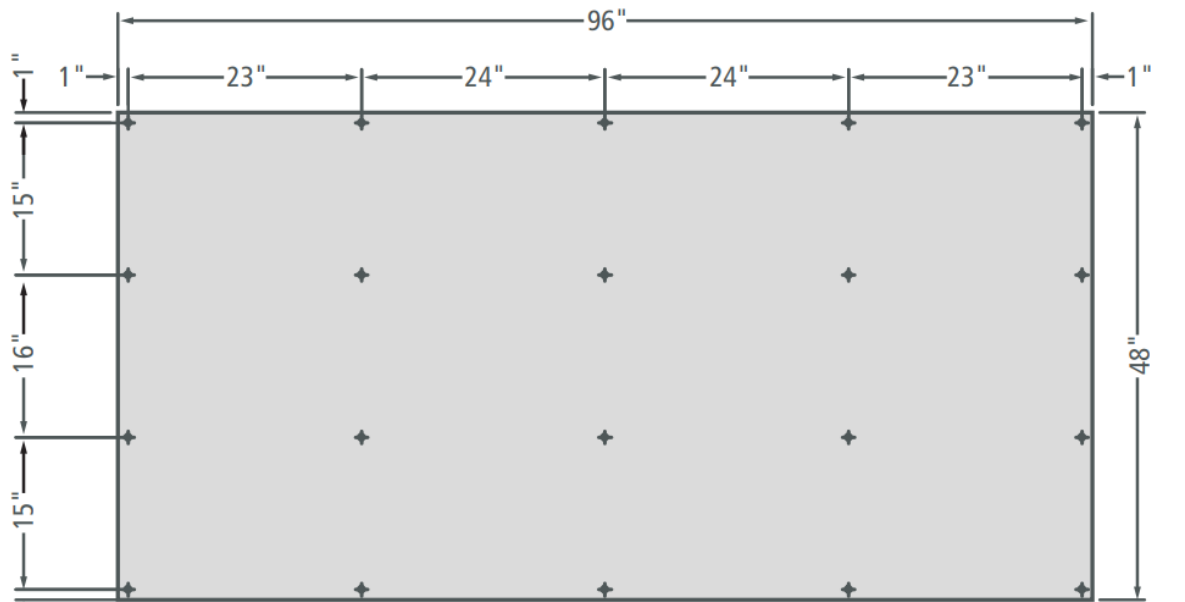

**Step 9. Railing Kit Installation.** The railing kit will include the lower post brackets, posts, horizontal railing tubes, hardware, and screws. The horizontal railing tubes come as a standard length and will need to be cut to size once the posts are in position. The horizontal railing tubes are held in place with the supplied TEK screws for easy yet secure assembly. Holes in the I-beams for the lower bracket to attach to are pre-drilled so that the location of each post is predetermined. (If for some reason your post location is not going to work because of an obstruction, you can relocate the post by drilling new holes as needed. Be aware that there are regulations pertaining to the distance from post to post being 8' or less.)

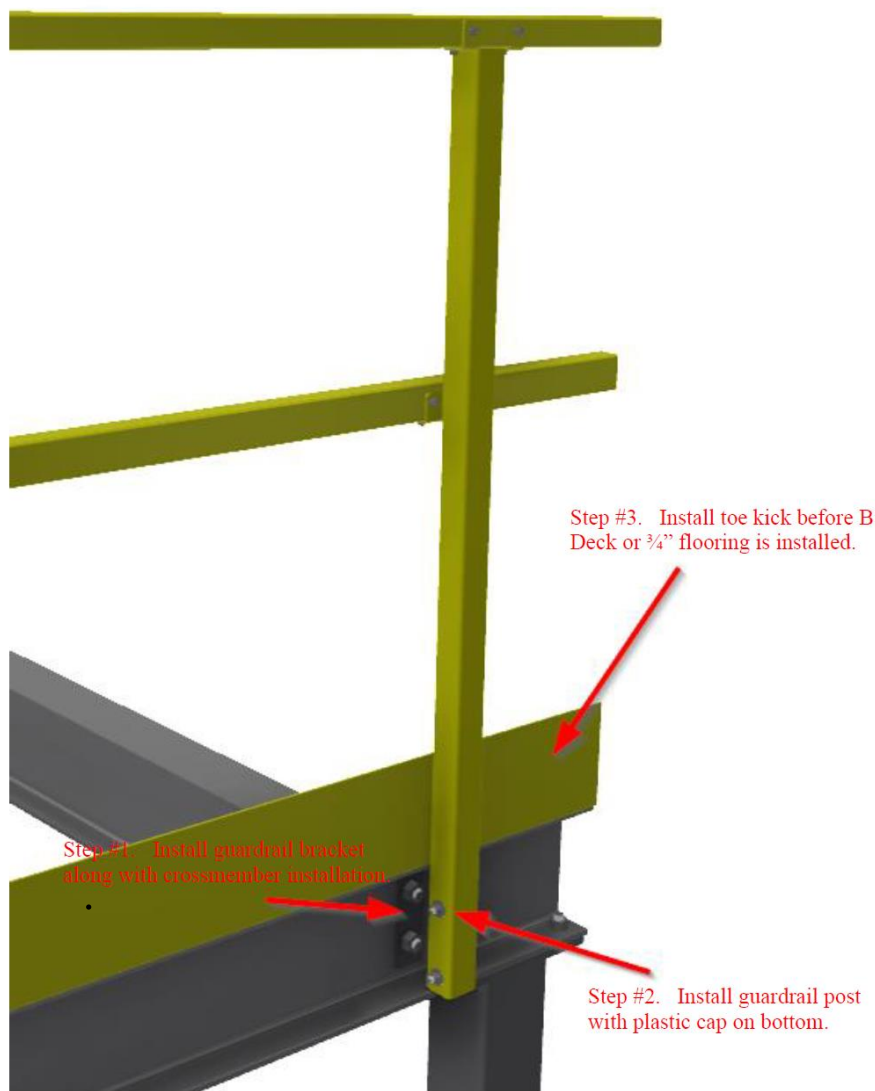



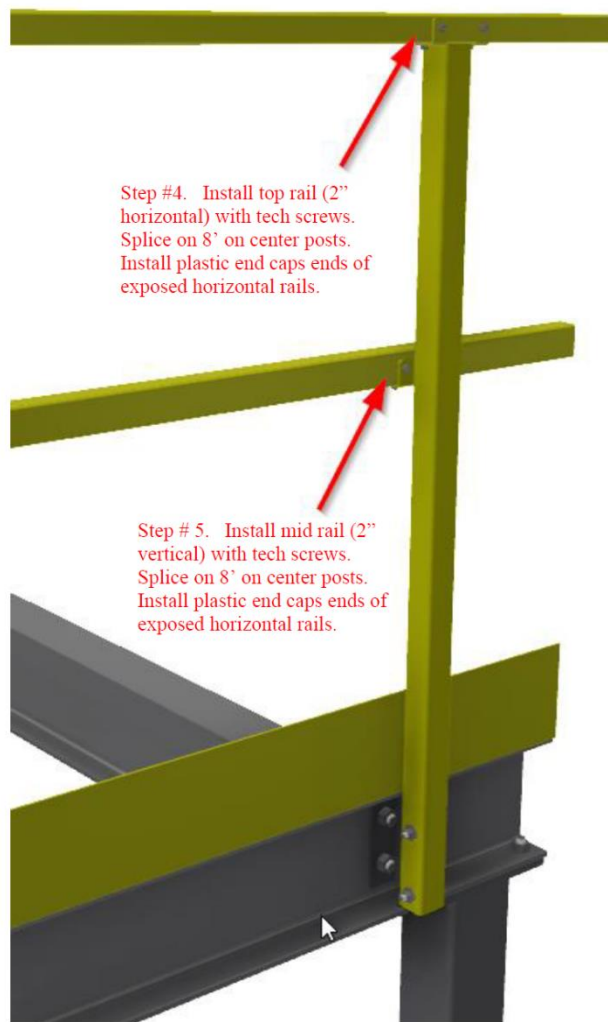

Step #4. Install top rail (2" horizontal) with tech screws. Splice on 8' on center posts. Install plastic end caps ends of exposed horizontal rails.

Step # 5. Install mid rail (2" vertical) with tech screws. Splice on 8' on center posts. Install plastic end caps ends of exposed horizontal rails.

**Final Step-----Drill and install remaining anchors at each column.**

**Stairways and Gates.** Stairways and gates may be part of your order. This assembly information will be given to you in a separate instruction manual specific to your purchase.

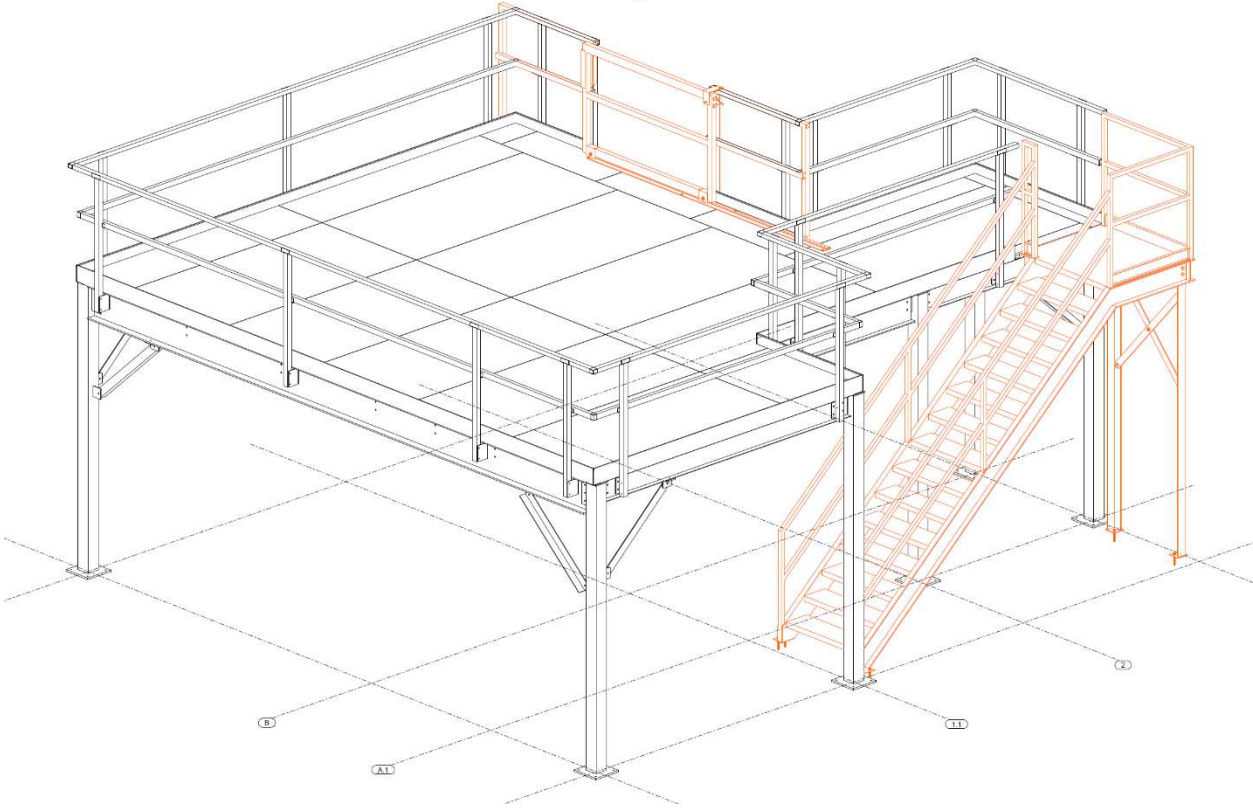



# Warranty Statement



## Structural Space Five Year Mezzanine and Stairway Parts & Workmanship Warranty

Unless otherwise specified, PWI guarantees that the product is free from material defects in design, materials, and workmanship under normal use, proper maintenance and service. A corrosive or abrasive atmosphere is not normal. This warranty will not apply to any product that has been repaired or altered outside of PWI plant, or without PWI's instructions, or in any way in PWI's judgment, to affect its serviceability or that were subject to misuse, negligence or accident, or products operated contrary to instructions. This warranty is strictly limited to Five years. Within ten days after a defect is found or reasonably should have been found, warrantee must deliver a written notice to PWI. The defective product or parts will be returned f.o.b., PWI factory. If any requested warranty information is not received in writing by PWI in the time requested, then this constitutes a waiver of any acceptance of the item by the user. Defective items will be repaired or replaced and will be returned f.o.b. PWI factory. If PWI, at its discretion finds the warranty claims to be justifiable, PWI will compensate by means of replacing or repairing faulty products or components, free of charge. The sole liability of PWI for warranty claims is limited to those listed here. In no event will PWI be liable for damages in excess of the original sale price of the defective product, or for any consequential damages. Nor will PWI be liable for any special or other work done unless specifically agreed to in writing. Should the warrantee destroy, intentionally or not, any part of the warranted product, or any evidence concerning the origin of an alleged defect, or try to conceal evidence of causation, this warranty is cancelled, and warrantee will have no claim against PWI whatsoever. Any interpretation of this warranty shall be done in common pleas court in Indianapolis under Indiana law.

**ALL OTHER REPRESENTATIONS, EXPRESS OR IMPLIED, WARRANTY, OR LIABILITY RELATING TO THE CONDITION OR USE OF THE PRODUCT ARE SPECIFICALLY DISAVOWED, AND IN NO EVENT SHALL PWI BE LIABLE TO BUYER, OR ANY THIRD PARTY, FOR ANY DIRECT OR INDIRECT CONSEQUENTIAL OR INCIDENTAL DAMAGES.**

Questions? Concerns? Comments? Please call (574) 646-2015

